

FOR **HITACHI** INVERTER

SJ-FB (Feed-Back Board)

INSTRUCTION

HITACHI

NB616XB

Thank you for purchasing the SJ-FB (HITACHI FEED-BACK BOARD).

This manual explains the operation of the feed-back board for use with

SAFETY

To get best performance with **SJ-FB (Feedback Board)**, read this manual, the SJ300 Instruction Manual, and all of the warning labels attached to the inverter carefully before installation and operation, and follow the instructions exactly. Keep this manual handy for your quick reference.

Definitions and Symbols

A safety instruction (message) is given with a hazard alert symbol and a signal word -

WARNING or **CAUTION**. Each signal word has the following meaning throughout this manual.



This symbol means hazardous high voltage. It used to call your attention to items or operations that could be dangerous to your and/or other persons operating this equipment. Read these messages and follow these instructions carefully.



This is the "Safety Alert Symbol." This symbol is used to call your attention to items or operations that could be dangerous to your and/or other persons operating this equipment. Read the messages and follow these instructions carefully.



WARNING

WARNING

Indicates a potentially hazardous situation which, if not avoided, can result in serious injury or death.



CAUTION

CAUTION

Indicates a potentially hazardous situation which, if not avoided, can result in minor to moderate injury, or serious damage of product.

The matters described under  **CAUTION** may, if not avoided, lead to serious results depending on the situation. Important matters are described in **CAUTION** (as well as **WARNING**), so be sure to observe them.

NOTE

NOTE

Notes indicate an area or subject of special merit, emphasizing either the product's capabilities or common errors in operation or maintenance.



HAZARDOUS HIGH VOLTAGE

Motor control equipment and electronic controllers are connected to hazardous line voltages. When servicing drives and electronic controllers, there might be exposed components with cases or protrusions at or above line potential. Extreme

care should be taken to protect against shock. Stand on an insulating pad and make it a habit to use only one hand when checking components. Always work with another person in case an emergency occurs. Disconnect power before checking controllers or performing maintenance. Be sure the equipment is properly grounded. Wear safety glasses whenever working on electronic controllers or rotating electrical equipment.

Revision History Table

No	Revision Contents	The Date of Issue	Operation Manual No.
1	Initial Release of Manual NB616X	Feb. 2000	NB616X
A	Revision A, by P. Curtis/Hitachi America, Ltd.	August 2000	NB616XA
B	Revision B, by P. Curtis/Hitachi America, Ltd.	August 2001	NB616XB

 **WARNING**

Only qualified personnel should carry out wiring work.
Otherwise, there is a danger of electric shock and/or fire.

Implement wiring **after** checking that the power supply is off.
Otherwise, there is a danger of electric shock and/or injury.

Be sure not to touch inside the inverter case and terminals of the option board while the inverter is energized.
Otherwise, there is a danger of electric shock and/or injury.

Be sure not to remove the encoder line and feedback board during operation.
Otherwise, there is a danger of electric shock and/or fire.

Do not perform maintenance or inspection until 10 minutes or more after turning off the input power supply.
Otherwise, there is a danger of electric shock

Make sure that only qualified persons will perform maintenance, inspection and part replacement. Before starting work, remove metallic objects from your person. Be sure to use tools protected with insulation
Otherwise, there is a danger of electric shock and/or injury.

Never modify the unit.
Otherwise, there is a danger of electric shock and/or injury.

Be sure to implement wiring **after** installing the inverter body.
Otherwise, there is a danger of electric shock and/or injury.

 **CAUTION**

Do not allow materials such as cutting waste, welding sputter, wire fragments, solder balls, dust etc. to come into contact with the unit.
There is a fire risk.

Inverter main body and option board must be mounted securely.
There is a risk of intermittent connection due to vibration.

Tighten the screws of the encoder line on the option board so that there is no loose connection.
There is a risk of intermittent connection due to vibration.

Confirm that the power supply rating of the encoder is the same as the option card (DC 5V).
Otherwise, there is the danger of damage, injury and/or fire.

Make sure that the direction of the motor is correct.
There is a danger of injury or machine damage.

Make sure there is no abnormal noise or vibration during operation.
There is a danger of injury or machine damage.

CONTENTS

Contents	PAGE
Chapter 1 GENERAL DESCRIPTIONS	7
1.1 Inspection upon unpacking	7
1.2 Inquiries and Warranty	7
1.2.1 Inquiries	7
1.2.2 Warranty	7
Chapter 2 OUTLINE OF SJ-FB	8
Chapter 3 INSTALLATION	9
Chapter 4 WIRING AND CONNECTION	10
4.1 Terminal Assignments of the SJ-FB Board	10
4.2 Function Explanation of the Terminals	11
4.3 Terminal Connections	12
Chapter 5 SETTINGS	14
5.1 Setting the DIP switches	14
5.2 Initial Settings	14
5.3 Inverter Configuration Parameters for the SJ-FB board	15
5.4 Setting Flowchart for the DIP Switches	18
Chapter 6 OPERATION	19
Chapter 7 FUNCTIONS	21
7.1 Orientation function	21
7.1.1 Function outline	21
7.1.2 Data setting	23
7.2 Speed control (ASR)	24
7.3 Position control (APR) (Electronic gear function)	24
7.3.1 Function outline	24
7.3.2 Control mode setting	24
7.3.3 Data setting	25
7.3.4 Pulse train mode selection	28
7.4 Speed control (P/PI) switching function	29
7.5 Compensation of secondary resistor function 30
Chapter 8 PROTECTION FUNCTION	31
8.1 Action selection in case of option error	31
8.2 Causes and countermeasures of Option Board Errors	31
8.3 Warning display	31
Chapter 9 SPECIFICATIONS	32

1.1 Inspection upon unpacking

Handle with care. Please verify the contents of the package check for any damage that may have occurred during transportation.

(Package contents)

- | | |
|-----------------------------------|---|
| 1. SJ-FB (Feed back board) | 1 |
| 2. Instruction manual | 1 |
| 3. Board mounting screws (M3×8mm) | 2 |

Please contact your supplier or Hitachi Distributor immediately if anything is missing or broken.

1.2 Inquiries and Warranty

1.2.1 Inquiries

If you have any questions regarding damage of the unit, unknown parts, or general inquiries please contact your supplier or the local Hitachi Distributor with the following information.

- (1) Inverter Model
- (2) Production Number (MFG. NO)
- (3) Date of Purchase
- (4) Reason for Calling
 - Damaged part and its condition etc.
 - Unknown parts and their contents etc.

1.2.2 Warranty

The warranty period of the board is shown below.

- ✓ **1 year after normal installation, or 2 years from date of manufacture.**

However within the warranty period, the warranty will be void if the fault is due to:

- (1) Incorrect use as outlined in this manual, or attempted repair by unauthorized personnel.
- (2) Any damage to the board, other than from transportation (which should be reported immediately).
- (3) Operating the unit beyond the limits of the specifications.
- (4) Act of God (Natural Disasters: Earthquakes, Lightning, etc)

The warranty covers the board only, any damage caused to third party equipment by malfunction of the board is not covered by the warranty. Any examination or repair after the warranty period (one year) is not covered. Within the warranty period, any inspection and repair which shows the fault was caused by any of the items mentioned above, the inspection and repair costs are not covered. If you have any questions regarding the warranty please contact either your supplier or

the local Hitachi Distributor.

This manual describes the option board **SJ-FB** for the SJ300 series inverter.

This SJ-FB board, installed in an SJ300 inverter, detects the rotation speed of a motor by accepting pulses from a shaft-mounted motor encoder, achieving highly accurate speed regulation.

This SJ-FB board can also be used to control motor stop position by inputting 90 degree out-of-phase (quadrature) pulses, as well as for synchronized operation between multiple inverters (master/slave or electronic gear), orientation function, and external torque limit input

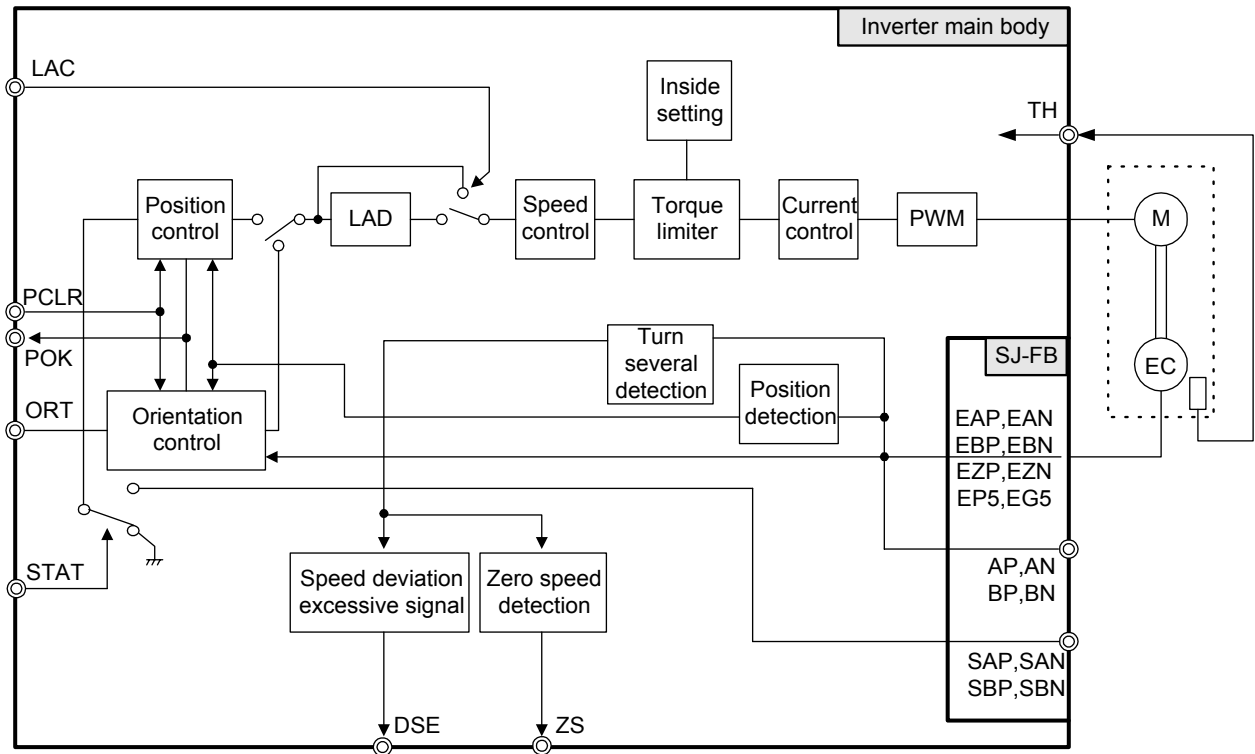

function.

Figure 2-1
Function Block Diagram

How to Mount the SJ-FB Board

Align the holes at the four corners of the SJ-FB board to the guide posts for positioning, in option port 1 or 2 of the inverter. Then gently push the option board into position, making sure the board is fully seated in its connector. Install two screws to secure the board to the inverter body as shown below.

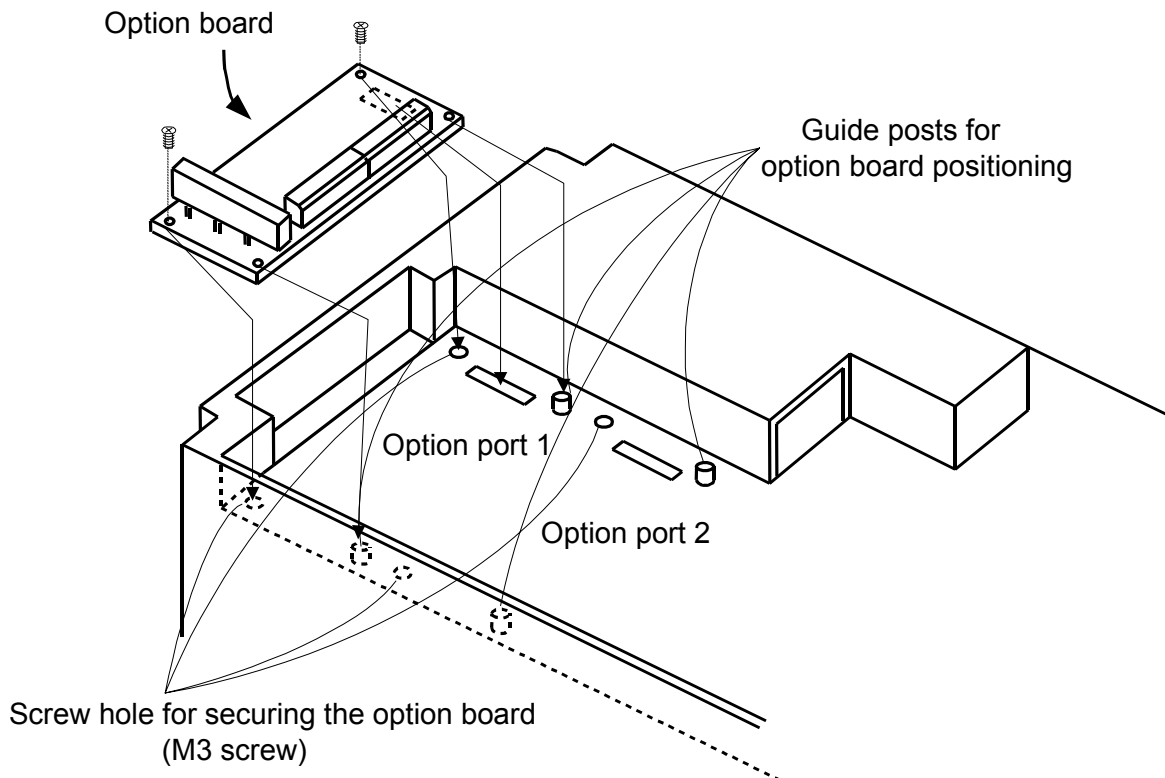
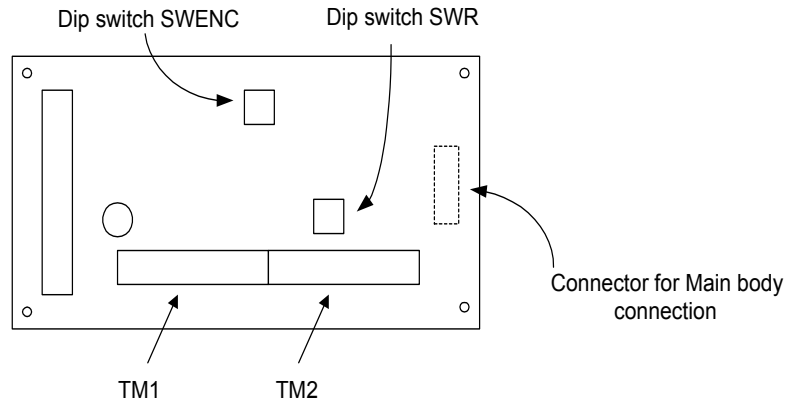

Figure 3-1 Option Board Installation

4.1 Terminal Assignments of the SJ-FB Board

Outlook of SJ-FB



TM1 terminal assignment

EP5	EG5	EAP	EAN	EBP	EBN	EZP	EZN
-----	-----	-----	-----	-----	-----	-----	-----

TM2 terminal assignment

SAP	SAN	SBP	SBN	AP	AN	BP	BN
-----	-----	-----	-----	----	----	----	----

Figure 4-1 Terminal assignments

4.2 Function Explanation of the Terminals

	Terminal	Code	Function	Common terminal	electrical specifications
Input terminals	Pulse train position command inputs	SAP SAN SBP SBN	Pulse train position command input (see page 16) <ul style="list-style-type: none"> • Mode 0 : 90 degree phase difference pulse (quadrature) • Mode 1 : Forward/Reverse signal; pulse train • Mode 2 : Forward pulse/Reverse pulse Built-in 150 ohm termination resistance can be turned ON or OFF with DIP switch SWR. Mode is selected via the pulse mode selection parameter (P013)		DC 5V receiver input (based on RS-422 standard)
	Encoder signal inputs	EAP EAN EBP EBN EZP EZN	A, B, Z: rotary encoder signal input		Photo coupler input (Compatible with the DC5V line driver type rotary encoder)
	Pulse train position command input permissive signal (Note 1)	STAT	Position control with pulse train input is valid when STAT is Turned ON. (Note 3)	CM1	Photo coupler input (Configure to an inverter intelligent input terminal.)
	Orientation signal: (Note 1)	ORT	Turn ON for orientation operation. (Note 3)		
	LAD cancel signal: (Note 1)	LAC	Turn ON to cancel LAD. (Note 3)		
	Position deviation clear signal: (Note 1)	PCLR	Turn ON to clear position deviation counter. (Note 3)		
	Output terminals	Encoder signal output	AP AN BP BN	Retransmits the input encoder signal (ratio 1:1).	
Power supply for encoder		EP5	DC +5V power supply	EG5	150mA max
Positioning completion signal (Note 2)		POK	Used for position control or orientation. Output ON when the position comes within the specified range (P017). (Note 3)	CM2	Open collector outputs (Configure to an inverter intelligent output terminal)
Speed deviation excessive signal (Note 2)		DSE	Output ON when the real rotation speed deviation from command speed exceeds (P027). (Note 3)		
Zero speed signal (note 2)		ZS	Output when the real rotation speed becomes zero speed detection level (C063). (Note 3)		

(Note 1): Valid when LAC is assigned to an intelligent **input** terminal of the inverter (SJ300).

(Note 2): Valid when POK is assigned to an intelligent **output** terminal of the main body (SJ300).

(Note 3): Refer to the configuration setting procedure for the inverter in the SJ300 Instruction Manual

Figure 4-2 Terminal wiring

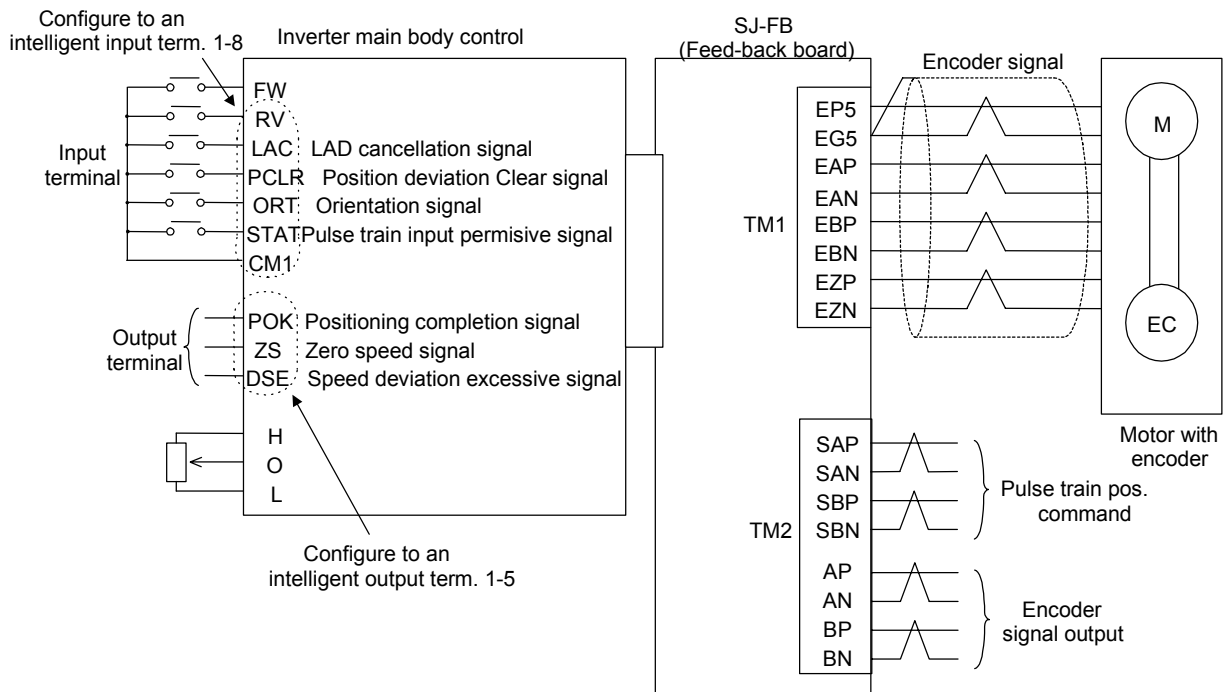

4.3 Terminal Connections

(Note 1) : Please refer to the SJ300 Instruction Manual for information about wiring the logic terminals.

(Note 2) : Use a shielded, twisted pair cable for the signal cables, and cut the shielded covering as shown in the diagram below. Make sure that the length of the signal cable is no more than 20 meters. If the length exceeds 20 meters, use a VX application control device RCD-E (remote control device) or CVD-E (signal isolation) to avoid malfunction caused by EMC noise or voltage drop. Also, the signal wire for the encoder should be shielded twisted pair line of 28 AWG (0.75mm²) or more, and the distance should also be less than 20m. If more than 20m, use a 5V line driver relay amplifier.

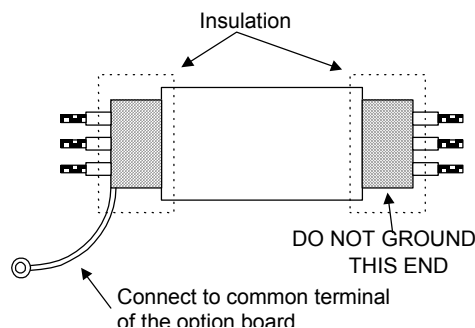

(Note 3) : Be sure to separate the power wiring from the control circuit wiring. If they have to be crossed, be sure that they cross at a right angle.

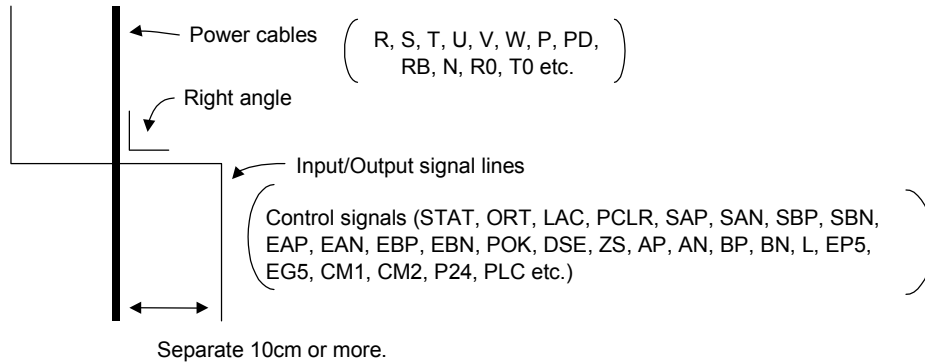

(Note 4) : Take care not to short circuit between the EP5 and EG5 terminals. There is a danger of malfunction.

(Note 5) : Isolate common signal for inverter analog signals (L terminal of the logic card of SJ300) from common terminal of the SJ-FB.

(Note 6) : Be sure to connect the encoder signal lines properly so that the relationship among their phases is as shown below during rotation of the motor (Standard EG5).

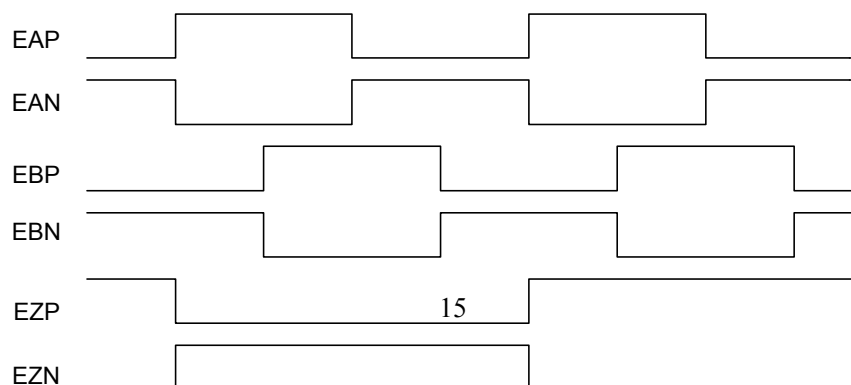

5.1 Setting the DIP Switches

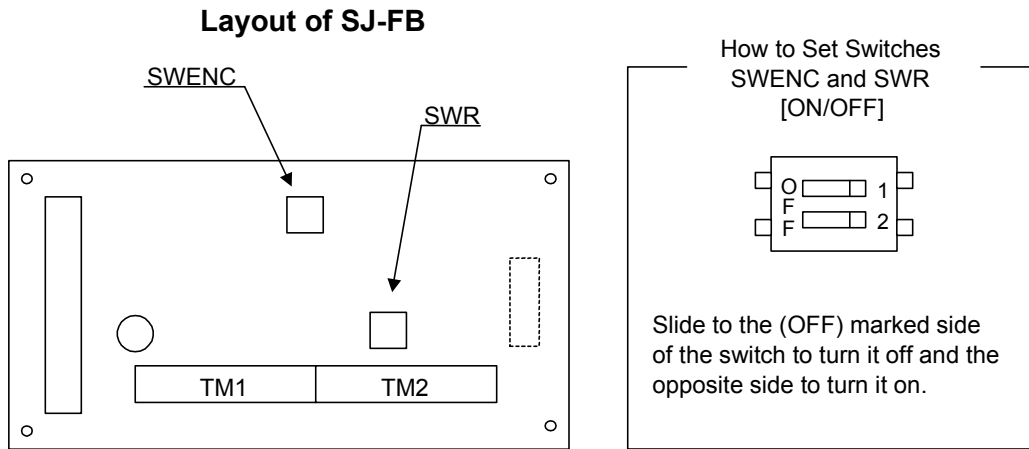

Figure 5-1 Switch arrangement figure

5.2 Switch Initial Settings

Setting item	Switch No.	Contents	
SWENC	1	ON	Detection of disconnected A or B signal (EAP-EAN or EBP-EBN) is valid.
		OFF	Detection of disconnected A or B signal (EAP-EAN or EBP-EBN) is invalid.
	2	ON	Detection of disconnected Z signal (EZP-EZN) is valid.
		OFF	Detection of disconnected Z signal (EZP-EZN) is invalid.
SWR	1	ON	Termination resistance is provided between SAP and SAN (150 ohms).
		OFF	No terminal resistance is provided between SAP and SAN.
	2	ON	Termination resistance is provided between SBP and SBN (150 ohms).
		OFF	No terminal resistance is provided between SBP and SBN.

(Note) : Default setting for all the switches is OFF.

5.3 Inverter Configuration Parameters for the SJ-FB Board

Code	Function name	Setting range	Initial data	Setting on run	Change mode on run
A044	1 st control method	00(VC) / 01(VP1.7power) / 02(Free V/f Setting) / 03(SLV) / 04(0Hz area SLV) / 05(V2)	00	-	-
H001	Auto-tuning mode selection	00(NOR : Invalid) / 01(NRT : not rotate) / 02(AUT : rotate)	00	-	-
H002	1 st motor constant selection	00(Hitachi standard motor constant) / 01(Auto-tuning data) / 02(Auto tuning data with online auto-tuning)	00	-	-
H003	1 st motor capacity selection	0.20 - 75.0(kW)	Setting on forwarding	-	-
H004	1 st motor pole selection	2/4/6/8 (Poles)	4	-	-
H005	1 st motor speed response setting	0.001 - 9.999 / 10.00 - 65.53	1.590	✓	✓
H006	1 st stabilized factor	0. - 255.	100.	✓	✓
H020	1 st motor R1 setting	0.000 - 9.999 / 10.00 - 65.53(Ω)	depends on the motor capacity	-	-
H021	1 st motor R2 setting	0.000 - 9.999 / 10.00 - 65.53(Ω)	depends on the motor capacity	-	-
H022	1 st motor L setting	0.00 - 99.99 / 100.0 - 655.35(mH)	depends on the motor capacity	-	-
H023	1 st motor I ₀ setting	0.00 - 99.99 / 100.0 - 655.35(A)	depends on the motor capacity	-	-
H024	1 st motor J setting	0.000 - 9.999 / 10.00 - 99.99 / 100.0 - 9999.(kgm ²)	depends on the motor capacity	-	-
H030	1 st motor R1 setting (Auto-tuning data)	0.000 - 9.999 / 10.00 - 65.53(Ω)	depends on the motor capacity	-	-
H031	1 st motor R2 setting (Auto-tuning data)	0.000 - 9.999 / 10.00 - 65.53(Ω)	depends on the motor capacity	-	-
H032	1 st motor L setting (Auto-tuning data)	0.00 - 99.99 / 100.0 - 655.35(mH)	depends on the motor capacity	-	-
H033	1 st motor I ₀ setting (Auto-tuning data)	0.00 - 99.99 / 100.0 - 655.35(A)	depends on the motor capacity	-	-

Code	Function name	Setting range	Initial data	Setting on run	Change mode on run
H034	The 1 st motor J setting (Auto-tuning data)	0.000 - 9.999 / 10.00 - 99.99 / 100.0 - 9999.(kgm ²)	depends on the motor capacity	-	-
H050	1 st PI control proportional gain setting	0.00 - 99.99 / 100.0 - 999.9 / 1000.(%)	100.0	✓	✓
H051	1 st PI control integral gain setting	0.00 - 99.99 / 100.0 - 999.9 / 1000. (%)	100.0	✓	✓
H052	1 st P control proportional gain setting	0.00 - 10.00	1.00	✓	✓
H070	PI control proportional gain switching	0.00 - 99.99 / 100.0 - 999.9 / 1000.(%)	100.0	✓	✓
H071	PI control integral gain setting	0.00 - 99.99 / 100.0 - 999.9 / 1000.(%)	100.0	✓	✓
H072	P control proportional gain setting	0.00 - 10.00	1.00	✓	✓
P001	Option 1 operation selection on error	00(TRP) / 01(RUN)	00	-	✓
P002	Option 2 operation selection on error	00(TRP) / 01(RUN)	00	-	✓
P011	Encoder pulse setting	128. - 9999. / 1000 - 6500 (10000 - 65000)(Pulse)	1024.	-	-
P012	Control mode selection	00(ASR Mode) / 01(APR Mode)	00	-	-
P013	Pulse train input mode selection	00(Mode 0) / 01(Mode 1) / 02(Mode 2)	00	-	-
P014	Stop position setting for orientation	0. - 4095.	0.	-	✓
P015	Frequency setting for orientation	0.00 - 99.99 / 100.0 - 120.0(Hz)	5.00	-	✓
P016	Direction setting for orientation	00(Forward) / 01(Reverse)	00	-	-
P017	Completion range setting for orientation	0. - 9999. / 1000(Pulse)	5	-	✓
P018	Completion delay time setting for orientation	0.00 - 9.99(s) (Note3)	0.00	-	✓
P019	Position selection for electronic gear	00(Position feed back side)/ 01(Position command side)	00	-	✓
P020	Numerator of ratio setting for electronic gear	0. - 9999.	1.	-	✓
P021	Denominator of ratio setting for electronic gear	0. - 9999.	1.	-	✓
P022	Feed forward gain setting for position control	0.00 - 99.99 / 100.0 - 655.3	0.00	-	✓
P023	Loop gain setting for position control	0.00 - 99.99 / 100.0	0.50	-	✓
P025	The 2 next resistance revision presence selection	00(Disable) / 01(Enable)	00	-	✓
P026	Over speed abnormal detection level	0.00 - 99.99 / 100.0 - 150.0(%) (Note 2) (Note 3)	135.0	-	✓
P027	Speed error over detection level	0.00 - 99.99 / 100.0 - 120.0(Hz) (Note 2)	7.50	-	✓

- (Note 1) : Please refer to the instruction manual of the inverter main body as to the setting procedure.
 (Note 2): When the over speed abnormal detection level (P026), the speed error over detection level (P027) are set 0, the Abnormal detection data processing will be invalid.
 (Note 3): Regarding the SJ-FB setting, there are some warning about what type of main body combines with the SJ-FB which is written following list.

No.	Item	Main body of SJ300 Production No (MFG No) (Note 4)	
		9 8 XXXXXXXXXXXXX 9 9 XXXXXXXXXXXXX 9 0 XXXXXXXXXXXXX 9 J XXXXXXXXXXXXX 9 K XXXXXXXXXXXXX 0 1 XXXXXXXXXXXXX	others
1	Completion delay time setting for orientation (P018)	Range of setting: 0.00 - 9.99 (X10(sec)) (Example) In order to operate the completion delay time setting for orientation for 1(sec). Set P018 setting which is written below. P018=1(sec)/10(sec)=0.10	Range of setting: 0.00 - 9.99 (X1(sec)) (Example) In order to operate the completion delay time setting for orientation for 1(sec). Set P018 setting which is written below. P018=1(sec) / 1(sec)=1.00
2	Over speed abnormal detection level	Range of setting: 0.0 - 150.0 (X100) (Example) In order to operate the over speed detection level at 66Hz while maximum frequency is 60Hz. Set P026 setting which is written below. P026=66Hz / 60Hz=1.1	Range of setting: 0.0 - 150.0 (X1%) (Example) In order to operate the over speed detection level at 66Hz, while maximum frequency is 60Hz. Set P026 setting which is written below. P026=66Hz / 60HzX100=110.0

(Note 4) The SJ300 Production number (MFG No) is printed on the main body of the SJ300 specifications label. Refer to figure 5-2(1), figure 5-2(2).

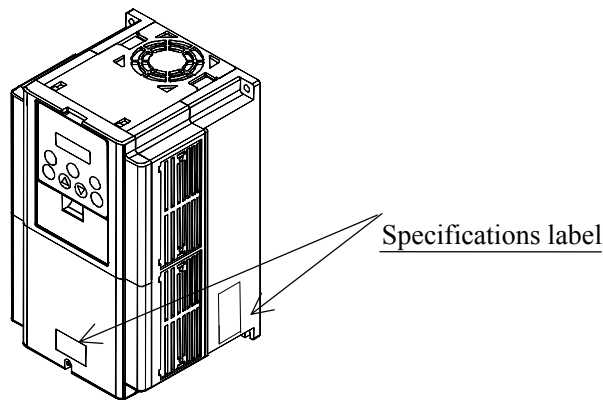

Figure 5-2(1) location of specification labels

	HITACHI
Inverter model	Model: SJ300-055HF
Maximum applicable motor	kW/(HP): 5.5/(7.5)
Input ratings	Input/Entrée: 50Hz, 60Hz 400-480 V 1 Ph A
	50Hz, 60Hz 400-480 V 3 Ph 13 A
Output ratings	Output/Sortie: 0, 1-400Hz V 3 Ph 12 A
Production number	MFG No. 94AT1234590001 Date: 9904
	Hitachi, Ltd, MADE IN JAPAN NE16989-27

Figure 5-2 (2) Contents of specification label

5.4 Setting Flowchart for the DIP Switches

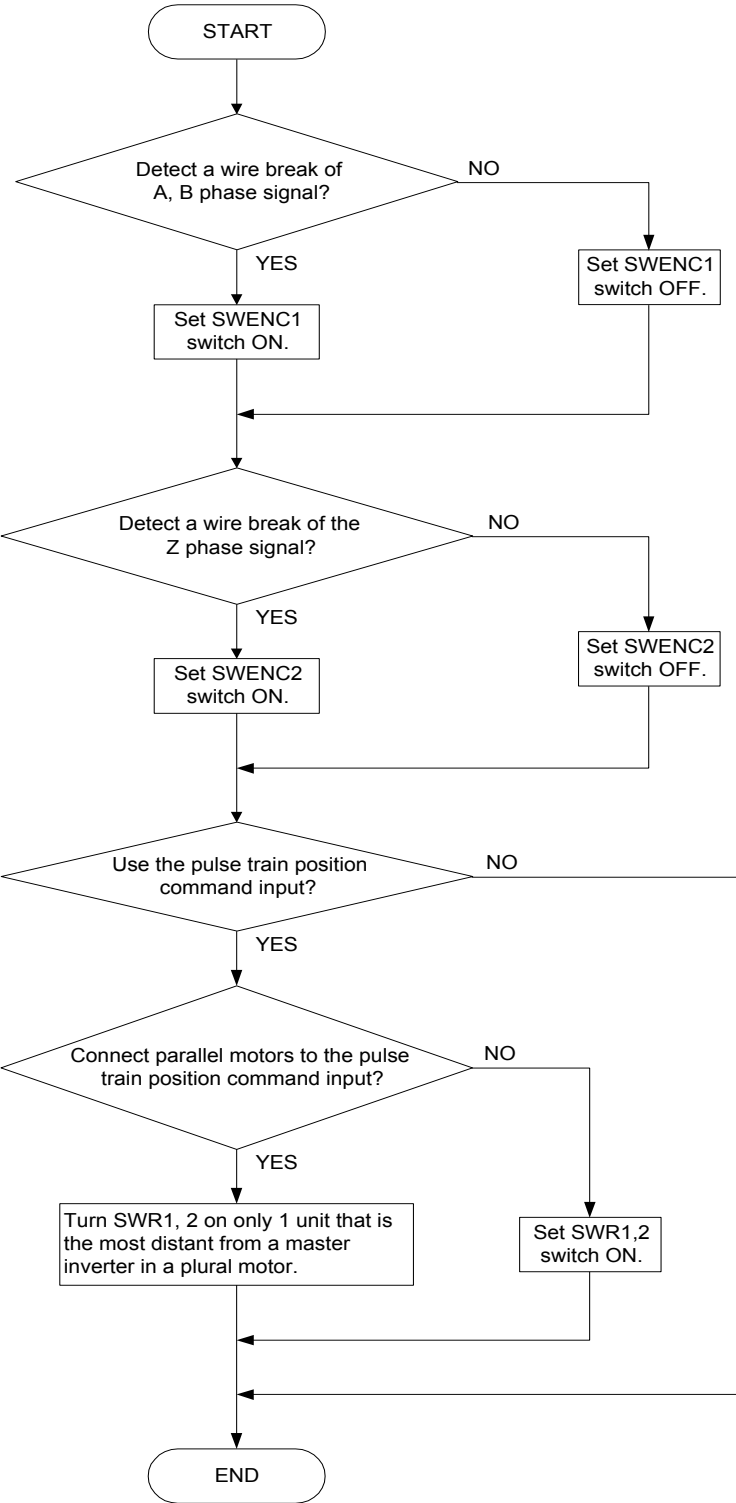

Figure 5-3 Switch setting flowchart

Refer to [Chapter 3 OPERATION] in the instruction manual for the SJ300 inverter before operating with this board. When the operation command is given from the terminal side of the inverter main body, operate with the following procedure.

<Procedure>

1. Turn ON the POWER switch of the inverter.
2. Set the control method (A044) in [05].
3. Set the necessary items according to the instruction manual "Chapter 4 FUNCTION EXPLANATION" of the inverter main body.
4. For speed control, operation is started when operation command of the inverter main body is turned on.
5. For position control, turn on the STAT terminal of SJ-FB and operation command of the inverter main body first of all. Next input the pulse train position command to SAP-SAN and SBP-SBN. Then the motor turns only the pulse that you input.

Confirm the following while trial operation.

- ✓ The motor accelerates normally.
- ✓ The motor rotates in the correct direction.
- ✓ Neither abnormal vibration nor noise is recognized in the motor.

If the motor doesn't accelerate normally or the inverter trips with overload, check the encoder for phase order. The normal phase order is that the waveform of phase A advances by 90° than that of phase B when the motor rotates forward.

(Note 1) : The monitor signal may not be output from FM terminal of inverter main body under vector control with sensor (A044=05). Please confirm the monitor output in this case.

(Note 2) : Please do not do the free run action by "RS terminal" of inverter main body. When you do this action, over current trip, or power element destruction may occur. Please use "FRS" the terminal when performing free run action.

(Note 3) : If the torque limit setting (b041-b044) is enlarged, over current trip would occur at the time of the motor added burden. In this case, please adjust the torque limit setting value.

(Note 4) : The motor constant data of the SJ300 series is the data at the time of base frequency 50Hz in the J1 motor made in Hitachi. Please put in the value that did it to motor constant I0 (H023) 0.7 times, in the case that you use it with base frequency 60Hz in the J1 motor.

(Note 5) : Please do the auto tuning, in the case that you do not understand the motor constant.

(Note 6) : If satisfactory performance can not be obtained, adjust the motor constants for the particular symptoms observed according to following table:

Inverter Status	Symptom Observed	Adjustment Guidelines	Parameter(s) to Adjust
At starting	Shock occurs at starting	Set “Motor constant J” higher gradually, up to 1.2 times the initially preset (default) value.	H024/H034
At deceleration	Instability of motor rotation	Set the speed response lower.	H005
		Set “Motor constant J” smaller than the initially preset value.	H024/H034
During torque limit	Insufficient torque during torque limit at low speed	Set overload restriction level lower than the torque limit level(s).	b022 b041-b044
At low frequency operation	Irregular rotation	Set “Motor constant J” higher than the initial preset (default) value.	H024/H034

7.1 Orientation function

This board is provided with the orientation function used to position the motor at a certain point during operation. This function can be used for replacing a component of the main axis of the subject machine tool for example.

7.1.1 Function outline

The orientation function maintains position which has decided with the position control after speed control operation. The action is shown in Figure 7-1.

Relation

- A044: 1st Control Method
- P014: Orientation Stop Position
- P015: Orientation Speed setting
- P016: Orientation Direction setting
- P017: Completion range setting
- P018: Completion delay time
- P023: Position loop gain
- C001-C008: Intelligent input terminal
- C021-C025: Intelligent output terminal

1. In the speed control operation period, inverter drives at constant speed with the orientation speed setting (P015). (Orientation mode becomes valid when turning RUN command ON under ORT is being ON.)
2. After arriving to the orientation speed setting(P015), the first coming the Z pulse is detected after that the control mode moves to the position control.
3. Inverter controls the motor to stop at a certain stop position which is set to (P014) during position control operation period.

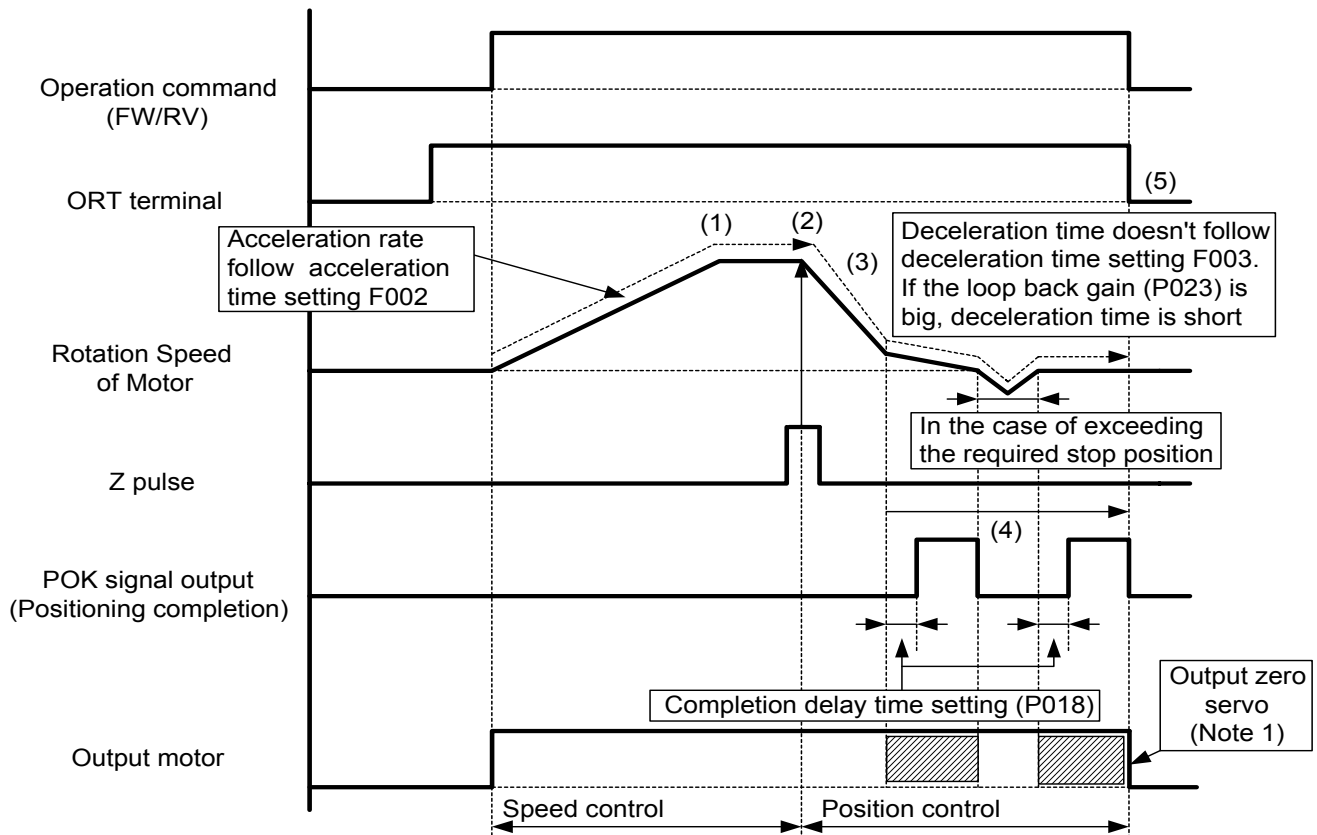

(Note 1) ⚠ Rotation speed of the motor is zero but inverter is outputting to the motor. Don't touch the motor power line. Otherwise, there is a danger of electric shock and/or injury.

(Note 2) In case of reoperating when the operation command is set terminal. Set the command operation(FW,REV)again.

Figure 7 - 1(1) Orientation and timing
(Action timing of when the ORT input signal is OFF during the orientation)

4. Inverter maintains the position after the completion, and outputs the 'position control completion (POK) signal' after the set value of 'delay time setting (P018). (Inverter drives the motor reverse and return to the required stop position in the case it exceeds the required stop position.)
5. When the ORT terminal is turned off, the inverter stops operation and the orientation mode is cleared.

(Note3) In case of using Z pulse, use 5V line driver type output for EZN-EZN input.

(Note 4): Action timing of when only the operation command is OFF during the orientation.

If only the operation command is OFF, the motor will stop (1). After that if the ORT terminal is OFF(2), POK signal output will be OFF (3).

(While ORT terminal is ON. Due to the orientation mode is running, even though only the operation command is OFF, the POK signal output (4) keep ON within the completion range.

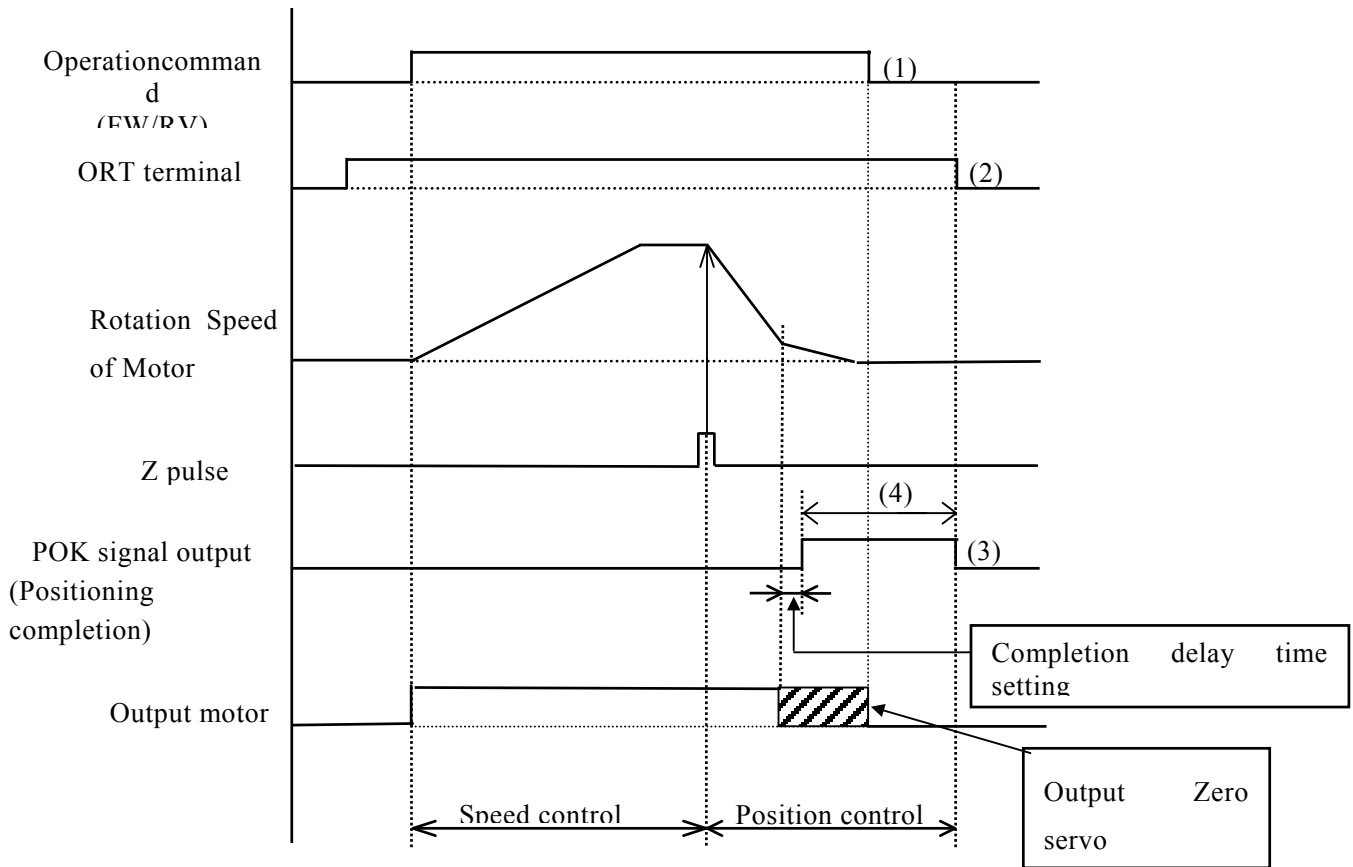



Figure 7 - 1(2) Orientation and timing

(Action timing of when only the operation command is OFF during the orientation.)

- (Note 5)  Rotation speed of motor is zero but inverter is outputting to the motor. Don't touch the motor power line. Otherwise there is a danger of electric shock /Injury.

7.1.2 Data setting

Data setting related to speed control

Setting item	Function code	Setting Range, Setting Contents
Orientation speed setting (Note 1)	P015	0.00~99.99 / 100.0~120.0 (Hz)
Orientation direction setting (Note 2)	P016	0:Forward / 1:Reverse

(Note 1) : In order to stop the motor for setting position. (Motor takes 2 rotation to stop setting position) Don't set high frequency to the orientation speed setting. Otherwise it will be over-voltage protection trip.

(Note 2) : Turn direction of the motor while orientation is done based on the setting of P016.

Data setting related to position control

Setting item	Function code	Setting range, setting contents
Orientation stop position(Note 3)	P014	0. ~4095.
Completion range setting	P017	0~9999. / 1000 (10,000) (pulses) (Setting four times fairly of the encoder pulses)
Completion delay time (Note 4)	P018	0.00~9.99
Position loop gain(Note 5)	P023	0.00~99.99 / 100.0 (rad/s)

(Note 3) : The orientation stop position is to be set as 4096 of division (0~4095) per 1 turn toward forward from the original point. (It is 4096 division irrespective of the pulse number of the encoder.) The original point is where the pulse has input to EZP-EZN. Stoppage goal position is like shown in Figure 7-2 irrespective of the turn direction.

(Note 4) : It depends on what type of main body combines with the SJ-FB, the setting value conversion is different. Please refer to the (Note 3) of the "5.3 Items regarding the feed back board of the inverter main body".

(Note 5) : To improve the positioning accuracy. → Increase position loop gain (G).
When the motor is unstable. → Decrease position loop gain.

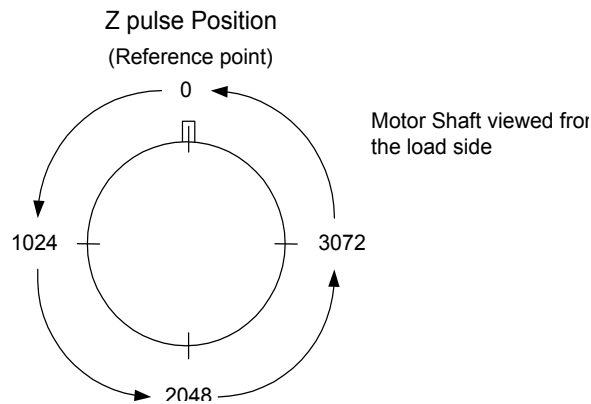

Figure 7-2 Concept of Orientation setting Position

Data setting of the input-output terminal

	Input-output terminal	Terminal assignment	Contents
Input	ORT terminal (ORT)	Set up 45 to one of them of C001~C008	ON : Orientation mode
Output	Positioning completion signal (POK)	Set up 23 to one of them of C021~C025	Output when it comes to the positioning completion range.

7.2 Speed control (ASR)

When the control mode selection (P012) is set to 00, operation mode becomes a speed control operation mode (ASR mode).

Please drive after setting up the frequency, operation command and each motor constant .

7.3 Position control (APR) (Electronic gear function)

When the control mode selection (P012) is set to 01, operation mode becomes a speed control operation mode (APR mode).

7.3.1 Function outline

This function generates the frequency based on the position command pulse which comes from the pulse train input from the terminal and position feed back pulse which is detected by the motor encoder, and performs the position control operation. It can be used as synchronous operation of main and sub motor. Also the turn ratio of main and sub motor can be changed by setting up the electronic gear ratio (N/D). (Electronic gear function)

7.3.2 Control mode setting

Inverter at the main motor (master inverter) can be set both as a speed control and position control. Please set up the inverter at the sub motor side (slave inverter) to a position control mode.

Relation

A044: 1st Control method
P012: Control mode selection
A001: Frequency command selection
A002: Operation command selection
F001: Frequency setting
F002: Acceleration time
F003: Deceleration time
F004: Operation direction selection
H002/H202-H052/H252:
Motor constant relation data

Relation

A044: 1st Control method
P012: Control mode selection
A002: Operation command selection
P017: Completion range setting
P018: Completion delay time
P019: Electronic gear position selection
P020: Electronic gear ratio numerator
P021: Electronic gear ratio denominator
P022: Feed forward gain
P023: Position loop gain
C001-C008: Intelligent input terminal
C021-C025: Intelligent output terminal
H002/H202-H052/H252:
Motor constant relation data

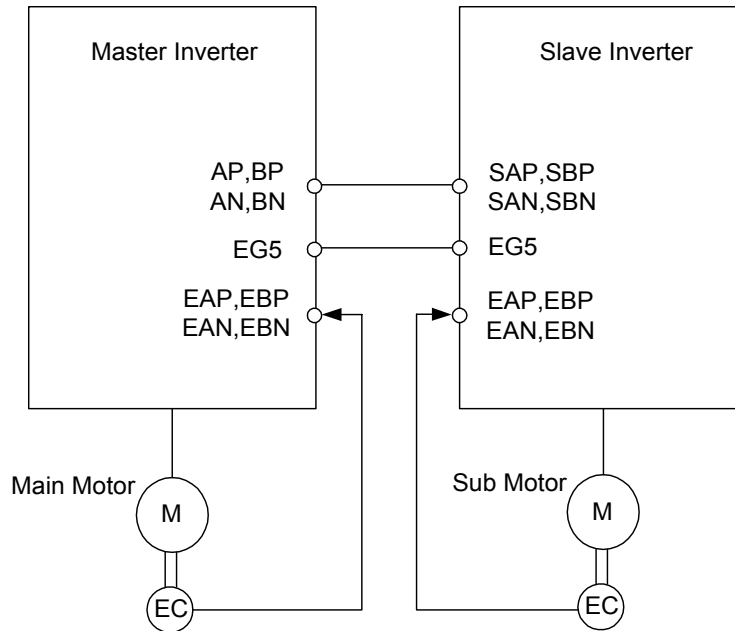

Figure 7-3 Wiring for Synchronized Operation

(Note) : Please connect EG5 of the main and sub inverter together to avoid malfunction caused by EMC noise.

7.3.3 Data setting

Data setting related to position control

Setting item	Function code	Setting range, setting contents
Feed-forward gain (Note 1)	P022	0.00~99.99 / 100.0~655.3
Position loop gain (Note 2)	P023	0.00~9.99 / 100.0 (rad/s)
Electronic gear position selection (Note 3)	P019	00: to the feed back side (FB) 01: to the position command side (REF)
Numerator of the electronic gear ratio (Note 3)	P020	1~9999
Denominator of the electronic gear ratio (Note 3)	P021	1~9999
Completion range setting	P017	0~9999. / 1000 (10,000) (pulse)
Completion delay time	P018	0.00~9.99 (s)

(Note 1) : We promote the adjustment from P022=2.00 at the time of the feed forward gain adjustment .To make the position deviation of the main and sub motor small, then increase feed forward gain. When the motor is unstable, then decrease feed forward gain

(Note 2) : We promote the adjustment from P023=2.00 at the time of the position loop gain adjustment. To get good accuracy of the position control then increase position loop gain, then to get much power to maintain the positioning then increase position loop gain. Motor is unstable due to too big position loop gain, then decrease position loop gain.

(Note 3) : N/D must be given as the ranges of $1/50 \leq (N/D) \leq 20$.

(N: Electronic gear ratio numerator, D: Electronic gear ratio denominator)

(Note 4) : It depends on what type of main body combines with the SJ-FB, the setting value conversion is different. Please refer to the (Note 3) of the “5.3 Items regarding the feed back board of the inverter main body“.

Data setting of input-output terminals

	Input-output terminal	With terminal assignment	Contents
Input	The pulse train position command input permission signal. (STAT)	Set '48' to one of C001~C008	Pulse train position command input is valid while ON.
Output	Positioning completion signal.(POK)	Set '23' to one of C021~C025	Output when it entered into the positioning completion range

Set '48' (the pulse train position command input permission signal (STAT)) to one of C001~C008. Pulse train position command input is valid only in the case that the STAT terminal is turned ON. In the case that the STAT terminal is OFF or unestablished, pulse train position command input is invalid.

Below the example of the proportion of the slave side turn number to the master side turn number by the setting of P019 ~ P021 is shown. (Yet, the encoder pulse number of the master side and slave side are same and be in the case of 1024 pulses.)

Position selection for electronic gear (P019)	01 (REF)	01 (REF)	00 (FB)	00 (FB)
Numerator of ration setting for electronic gear (P020)	1024	2048	1024	2048
Denominator of ratio setting for electronic gear (P021)	2048	1024	2048	1024
Slave side turn number to the master side turn number	1/2	2	2	1/2

Main Motor : Encoder pulse 1024 pulses

Sub Motor: Encoder pulse 3000 pulses

(Main motor rotation speed) : (sub motor rotation speed) = 2 : 1

Set the following for slave inverter in this case.

Electronic gear setting position (P019) : RET (command pulse side)

Electronic gear numerator (P020) : 3000

Electronic gear ratio denominator (P021) : $1024 \times 2 = 2048$

Figure 7-4 Control block diagram of the electron gear function (1)

Figure 7-5 Control block diagram of the electron gear function (2)

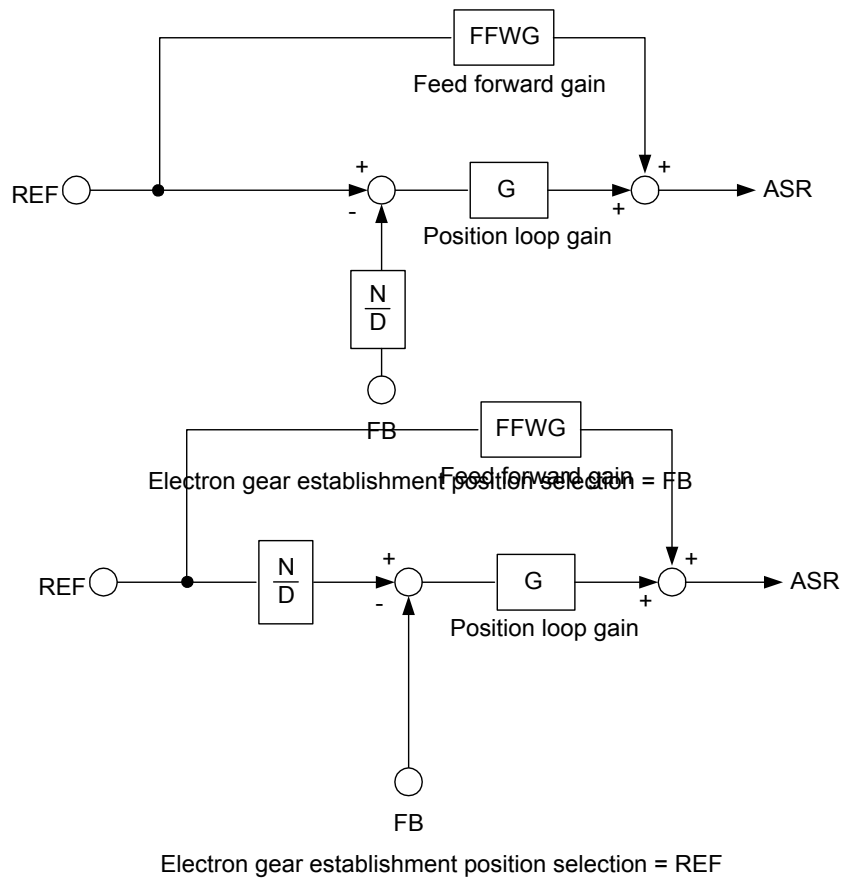

7.3.4 Pulse train mode selection

The following 3 ways of pulse line input can be selected by the setting of P013.

1) 90° phase difference pulse train (Mode 0)

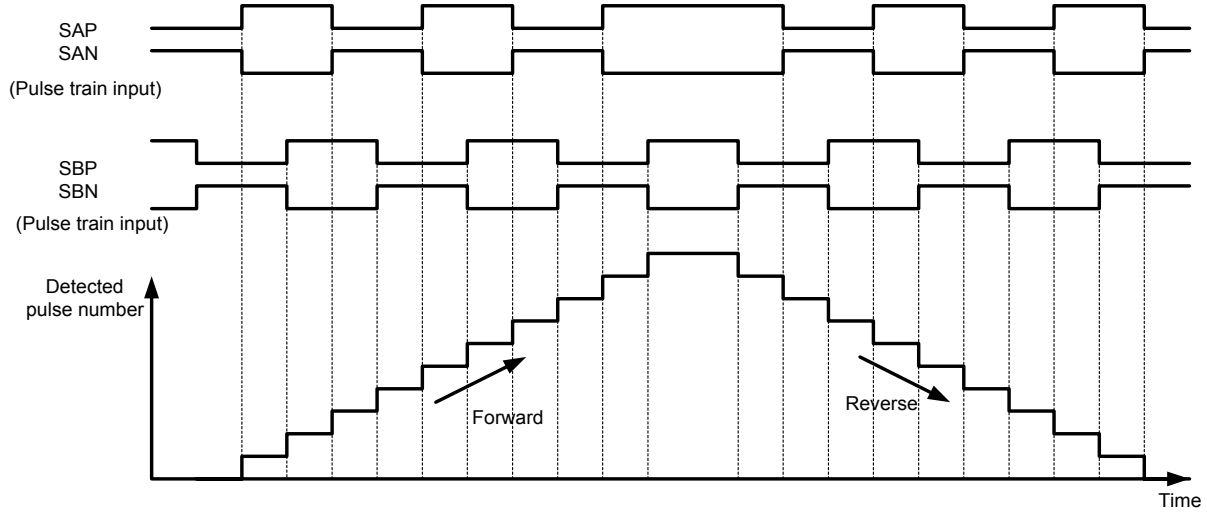

2) Forward/Reverse command + pulse train (mode 1)

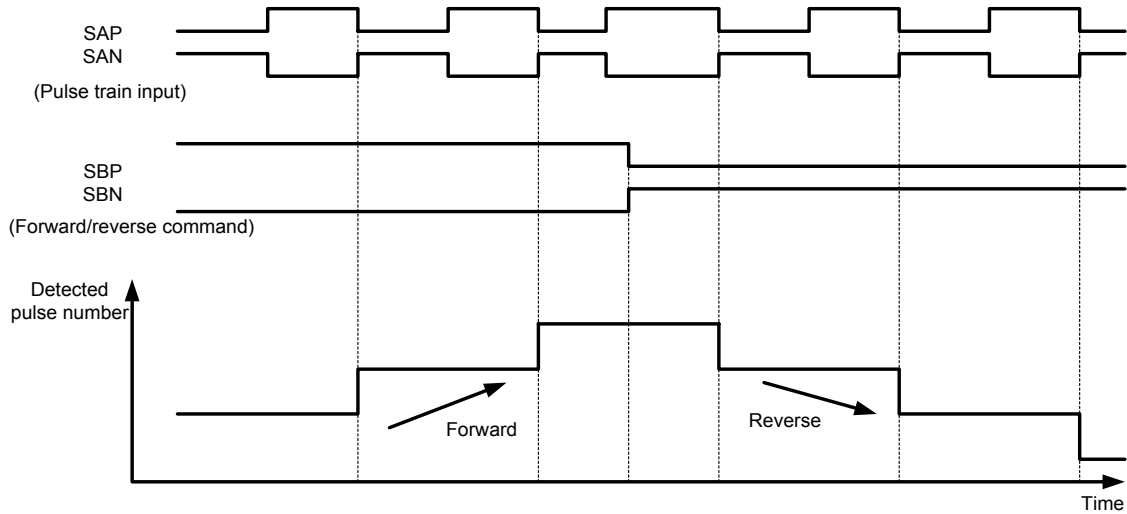

3) Forward pulse train + Reversion pulse train (mode 2)

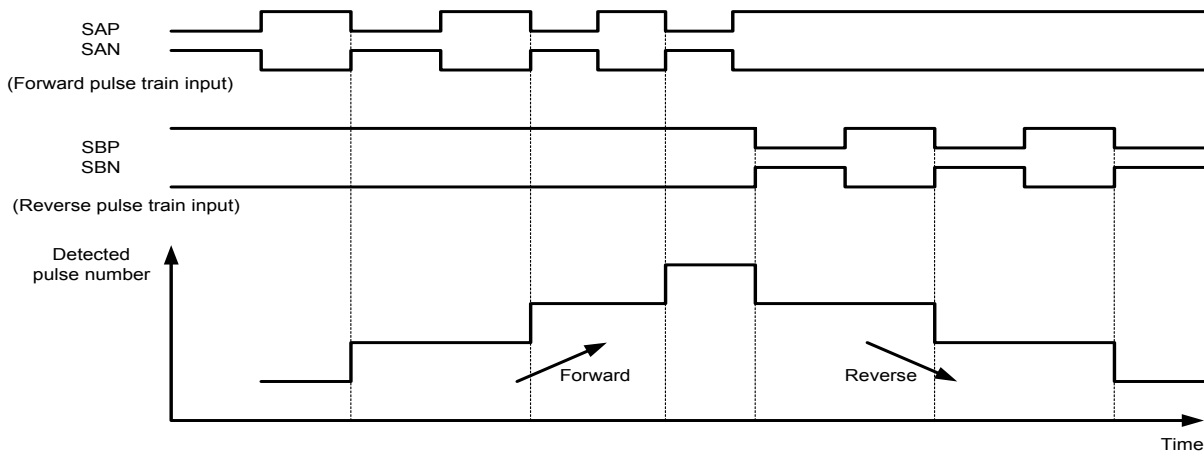

7.4 Speed control (P/PI) switching function

Speed control mode is normally controlled by proportional-integration compensation (Pi), which keeps the deviation between the actual speed and speed command becomes 0. Further, you can also achieve a propotional control function, which can be used as drooping operation (i.e. one load with several inverters) with this option card.

Relation
A044: 1 st Control Method
P052: 1 st Proportional gain

Set P/PI switching function to one of the intelligent input terminal 1~8 by the operator to achieve this function. (Input ‘43’ in one of C001~C008.) When this is turned on, control mode becomes proportion control (P).

Please set proportional gain(Kpp ; a value used to decide the speed change rate) to H052 by a digital operator. The relationship between the Kpp value and the speed change rate is shown below.

$$(\text{Speed Change Rate}) = \frac{10}{(\text{Kpp Set Value})} (\%)$$

Relationship between Kpp Value and Speed Change Rate

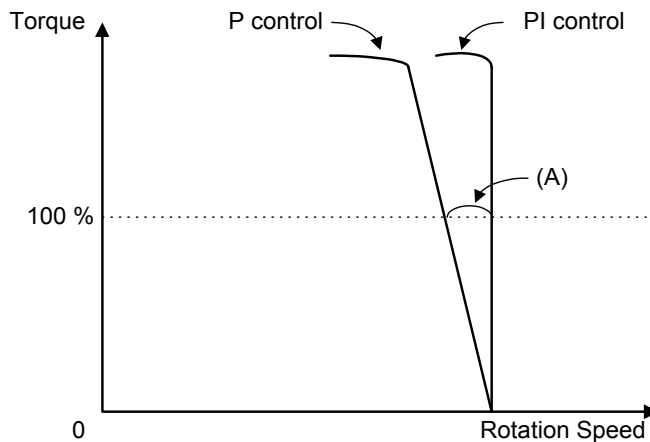

Figure 7-6 Torque characteristic (P/PI)

$$(\text{Speed Change Rate}) = \frac{\text{Speed Error at Rated Torque (A)}}{\text{Synchronous speed base frequency}}$$

Relationship between Speed Change Rate and Rated Rotation Speed

7.5 Compensation of secondary resistor function (Temperature revision)

Please use this function, if you want to do the temperature revision to restrain the speed fluctuation by the temperature change of the motor. (Please use the thermistor of the characteristic like type B that shows it below. (This thermistor is the characteristic of PE-41E made of a Shibaura electronics co.,Ltd.))

Relation	
P025:	Compensation of secondary resistor selection
b098:	Thermistor selection
b099:	Thermistor error level
C085:	Thermistor adjustment

1. Please wire the thermistor that is built to the motor to the inverter.

(Wiring between TH and CM1 of the terminal unit board of the main body)

2. Please set up it as follows.

P025.....01(valid) b098..... 02(NTC)

b099.....(This code is thermistor error level setting. Set the resistance value of temperature for trip according to thermistor methods.)

C085.....(Use this as gain adjustment.)

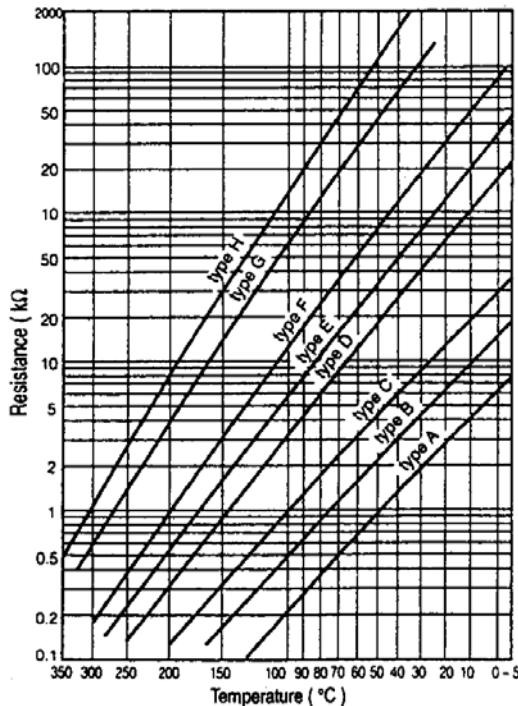

Figure 7-7 Resistor vs. Temperature Curves

(Note):Please wire it once again after the thermistor error occurrence level is changed, after you remove the wiring of the thermistor once, if the thermistor error occurred.

8.1 Action selection in case of option error

To ignore or make inverter trip can be selected in case of option error.

Item	Function code	Data	Contents
Action selection in case of option error	P001 / P002	00	TRP: Inverter trips and outputs alarm signal.
		01	RUN: Inverter ignores the option error and continues the operation.

(Note) : Inverter trips anyway in case of encoder line break error (E60, E70), SJ-FB abnormal connection (E69,E79) occurs, although action selection is set to 01 (RUN). Please refer to "Chapter 5.2 FEED-BACK BOARD INITIAL SETTINGS".

8.2 Causes and Countermeasures for Option Board Errors

When any of the following alarms occurs, the inverter displays the alarm cause and stops.

Display	Item	Contents	Processing
E60 (E70) (Note 1)	Encoder line break	Detect the line break or disconnection of the encoder line.	Check the encoder signal line and connection.
		Detect when there is an encoder failure. Detect when the specification of the encoder is not line driver output type.	Replace it to a suitable one.
		Detect when there is no Z pulse.	Turn SWENC-2 OFF on the option board.
E61 (E71) (Note 1)	Over speed	Detect when the motor rotation speed exceeds (maximum frequency (note 2))×(over speed error detection level (P026). (Note 3),(Note 4)	Adjust the Kp and J constants related to the speed control system to reduce overshoot.
E62 (E72) (Note 1)	Positioning error	Detect when the deviation of the current position and command value becomes more than 1,000,000 pulses during position controlling.	Increase the position loop gain. Decrease the numbers of the pulse train input per second.
E69 (E79) (Note 1)	connection error	Detect abnormal connection between the inverter main body and SJ-FB.	Check the connection between the inverter main body and SJ-FB.

(Note 1): Data in parentheses () applies when the option card is connected to option slot 2.

(Note 2): Frequency upper limit value (A061/A261) is reflected when it is set.

(Note 3): It depends on what type of main body combines with the SJ-FB, the setting value conversion is different.

Please refer to the (Note 3) of the “5.3 Items regarding the feed back board of the inverter main body“.

(Note 4): When the over speed error occurred . There is a possibility the over speed error occur again. Even though the trip is cleared during the motor free run. In this case stop the motor, then clear the trip please.

8.3 Warning display (Feed back option relation)

(Refer to the operation manual of the main body about the warning other than the following.)

The \square 009 is displayed in the case that it became orientation speed setting (P015) > the highest

frequency setting (A004). Please confirm the case, orientation speed setting (P015) and highest frequency setting (A004).

Product specification

Item		Specification
Speed control	Encoder feed-back:	<ul style="list-style-type: none"> • Standard encoder pulse number 1024 pulse/r • Max. input pulse 100k pulse/s
	Speed control system:	<ul style="list-style-type: none"> • Proportional-Integral (PI) / Proportional (P) control
Position control	Position command:	<ul style="list-style-type: none"> • Three kinds of pulse train input selectable by main body setting. Mode 0 : 90° phase difference pulse Mode 1 : Forward/Reverse signal pulse Mode 2 : Forward pulse/Reverse pulse • Max. input pulse 100k pulse/s
	Electronic gear:	<ul style="list-style-type: none"> • Pulse ratio A/B (A, B: 1~9999 selectable) • Setting range $1/50 \leq A/B \leq 20$
Orientation	Stop position:	<ul style="list-style-type: none"> • 4096 division against 1 rotation of the motor shaft (Note 1)
	Speed:	<ul style="list-style-type: none"> • Orientation speed and turn direction selectable
Protection function		<ul style="list-style-type: none"> • Encoder cable line break protection • Over speed protection (over speed error detection level (P026)) (Note 2) • Positioning error • Connection abnormal of SJ-FB

(Note 1): The main body setting or external input is selectable.

SJ-DG (digital input option board) is required in case of external input.

(Note 2): It depends on what type of main body combines with the SJ-FB, the setting value conversion is different.

Please refer to the (Note 3) of the “5.3 Items regarding the feed back board of the inverter main body“.