

# HITACHI INVERTER

## SJ200/L200 Series

### **SERVICE MANUAL** (ADJUSTMENT AND MAINTENANCE)

Model:

European Version

SJ200/L200-002NFE(F) to SJ200/L200-022NFE(F)

SJ200/L200-004HFE(F) to SJ200/L200-075HFE(F)

US Version

SJ200/L200-002NFU to SJ200/L200-022NFU

SJ200/L200-037LFU to SJ200/L200-075LFU

SJ200/L200-004HFU to SJ200/L200-075HFU

After reading this manual, keep it at hand for future reference

# HITACHI

NBS650X

# Appearance and name of each parts

**SJ200-002 - 007LFR**

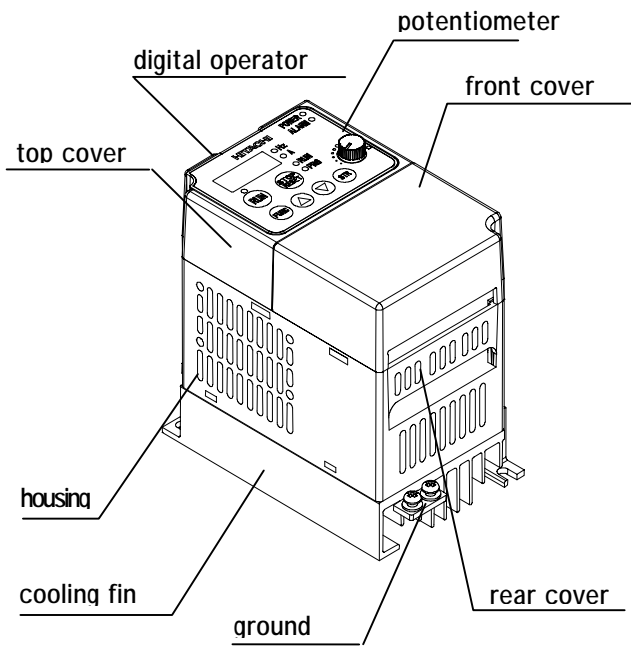

**SJ200-015 - 037LFR  
SJ200-004 - 037HFR**

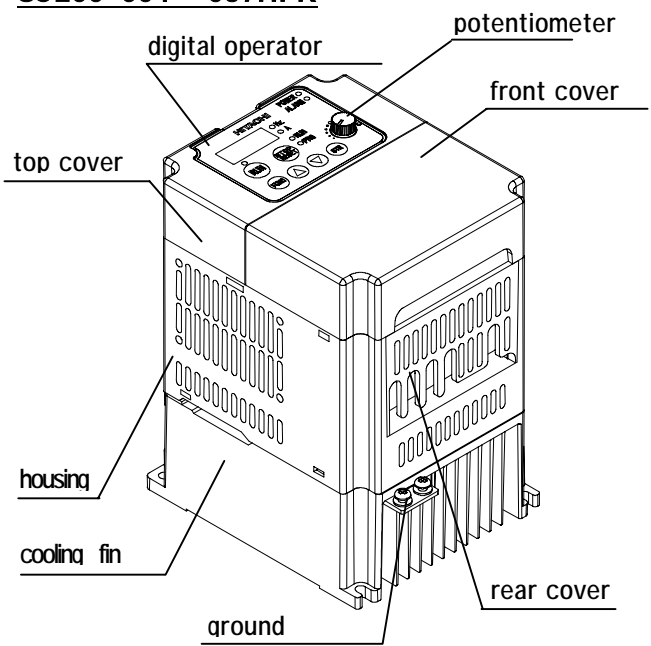

The front cover can be removed without any instruments. When you remove the front cover, you can set the mode switch and set wire at the control-terminal, the main-terminal and the intelligent relay output terminal.

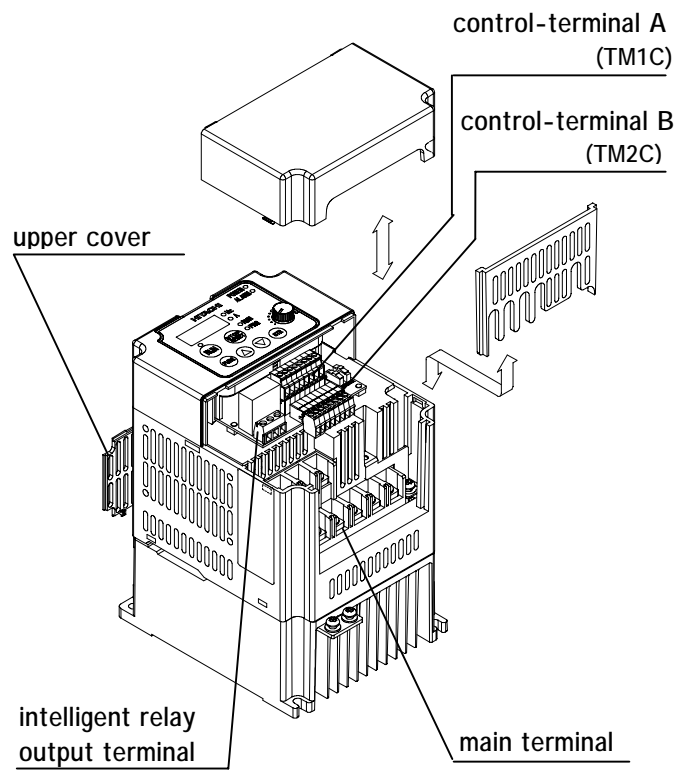
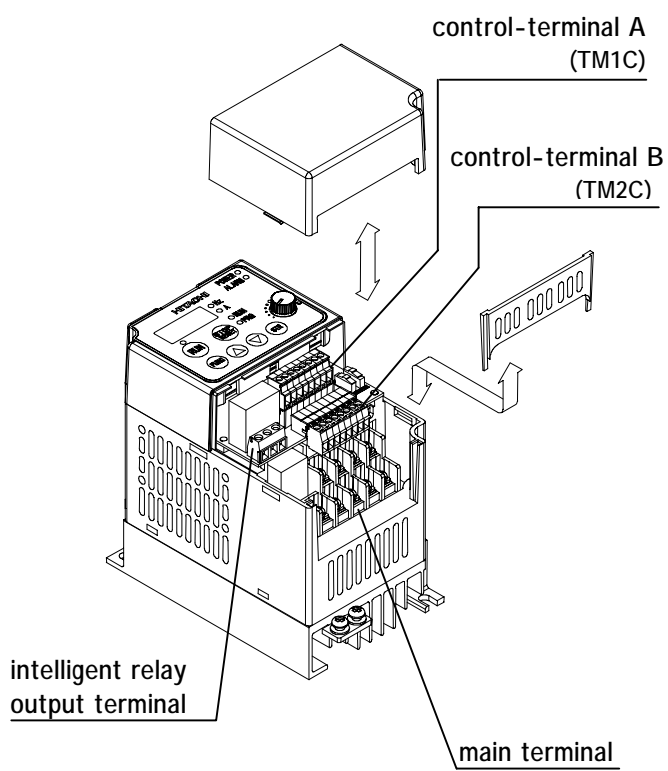

**Note:** The upper cover is for maintenance. Please do not remove.

**SJ200-055~075LFR**  
**SJ200-055~075HFR**

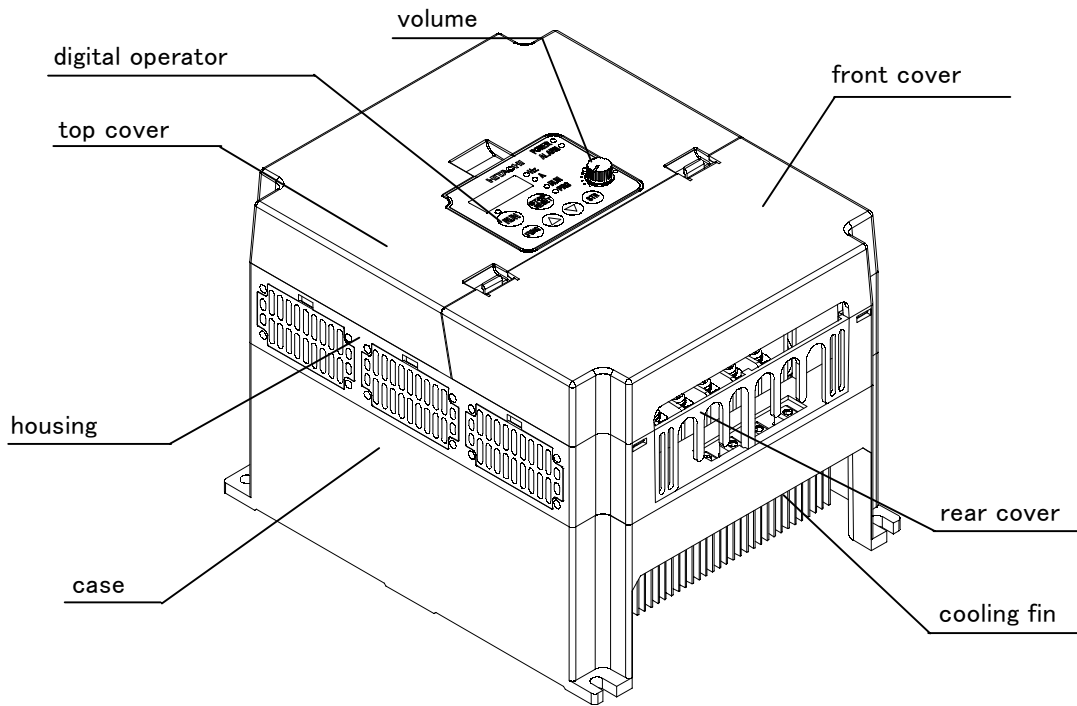

The front cover can be removed without any instruments. When you remove the front cover, you can set the mode switch and set wire at the control-terminal, the main-terminal and the intelligent relay output terminal.

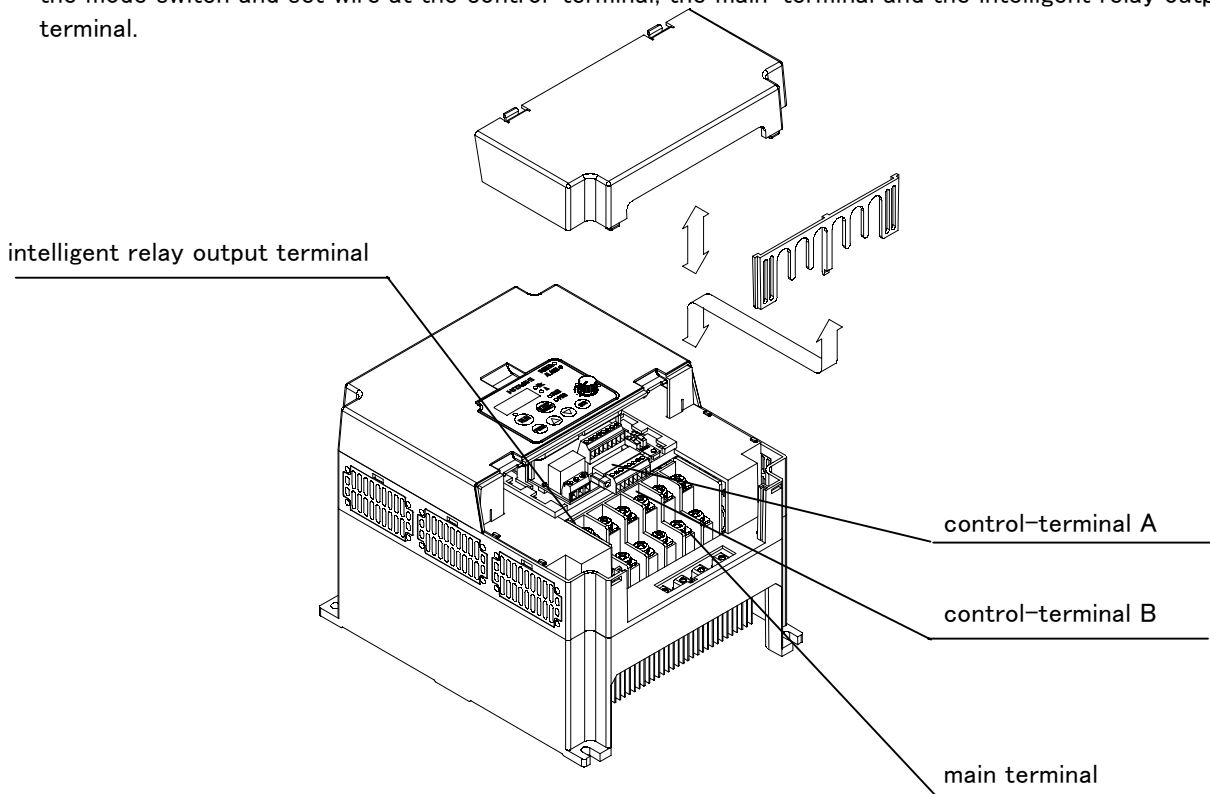

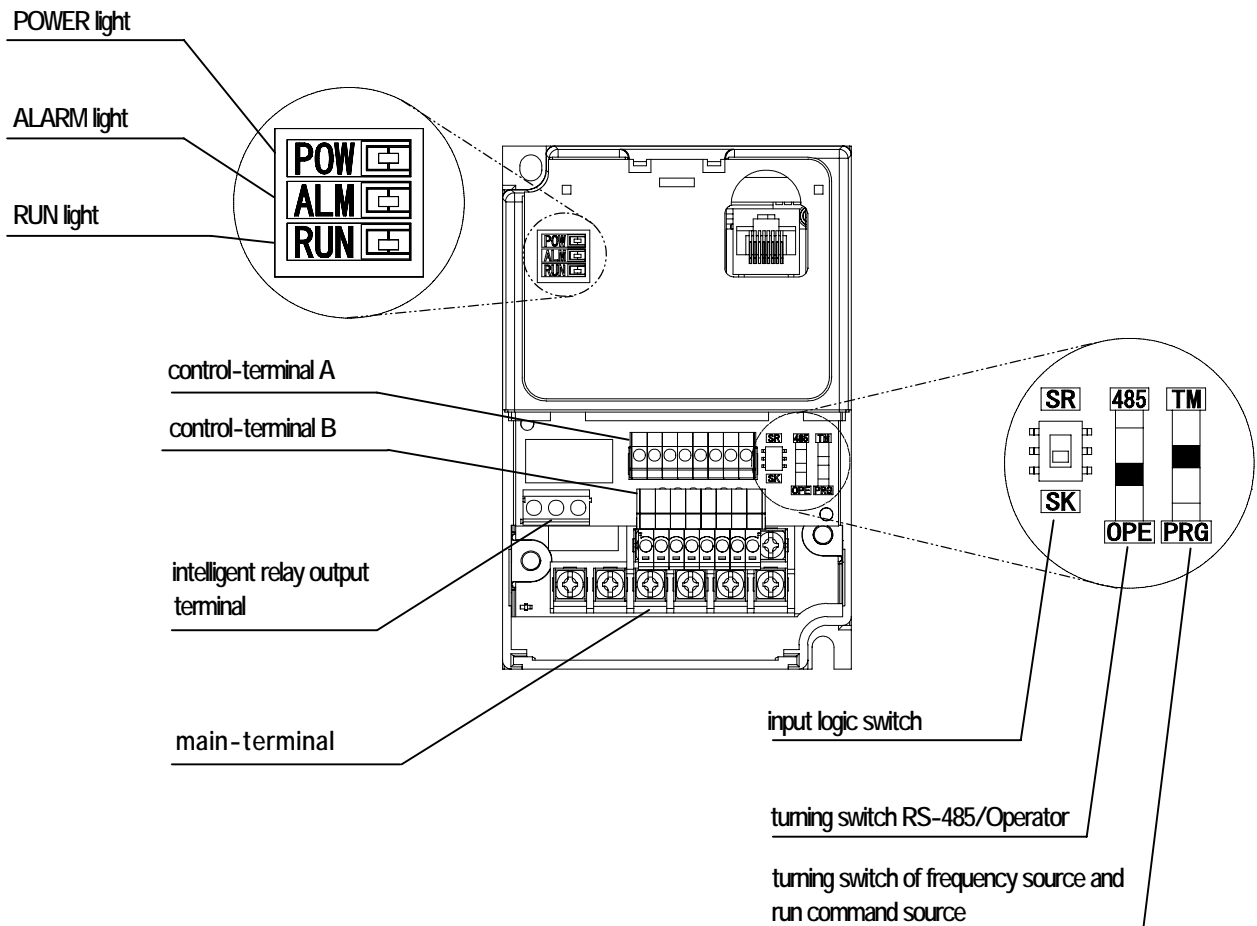
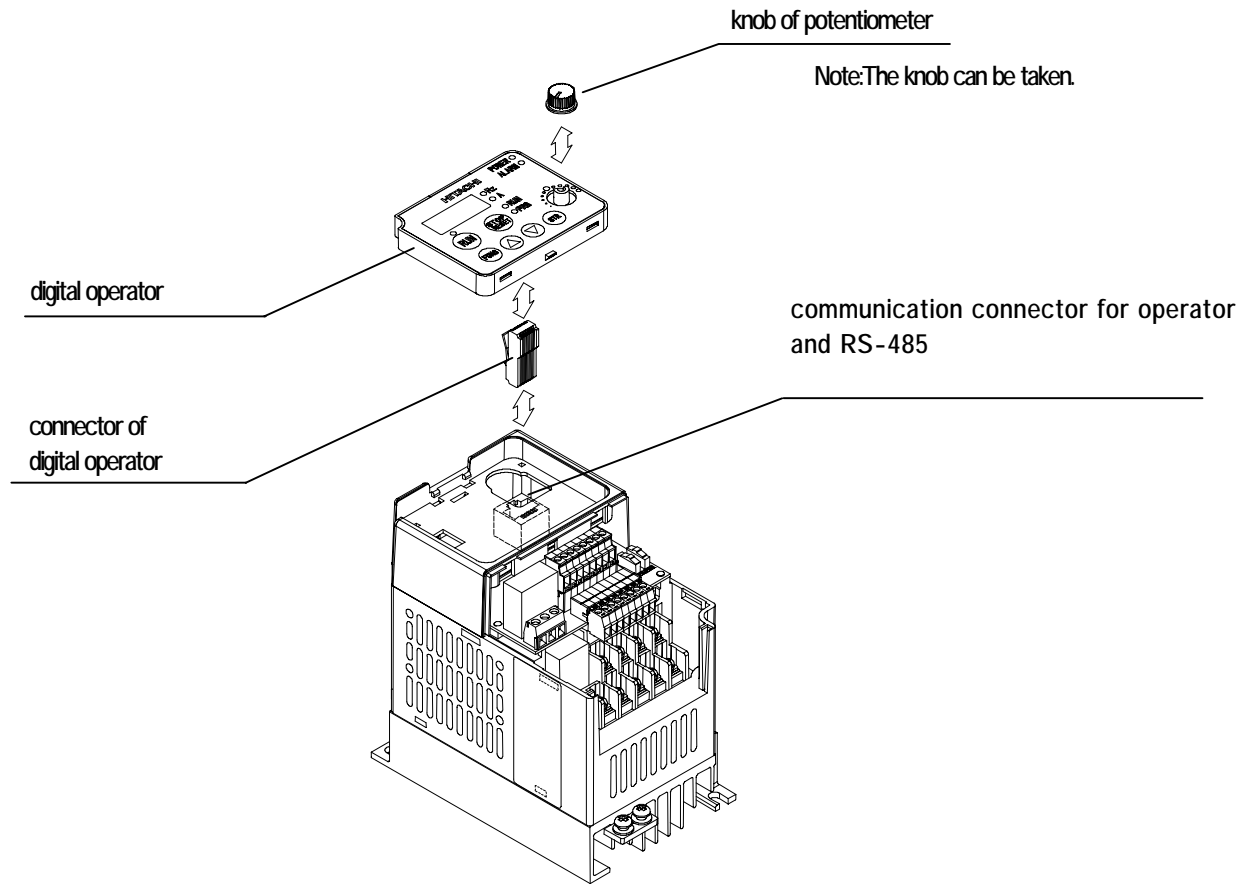

**L200-002~007LFR**

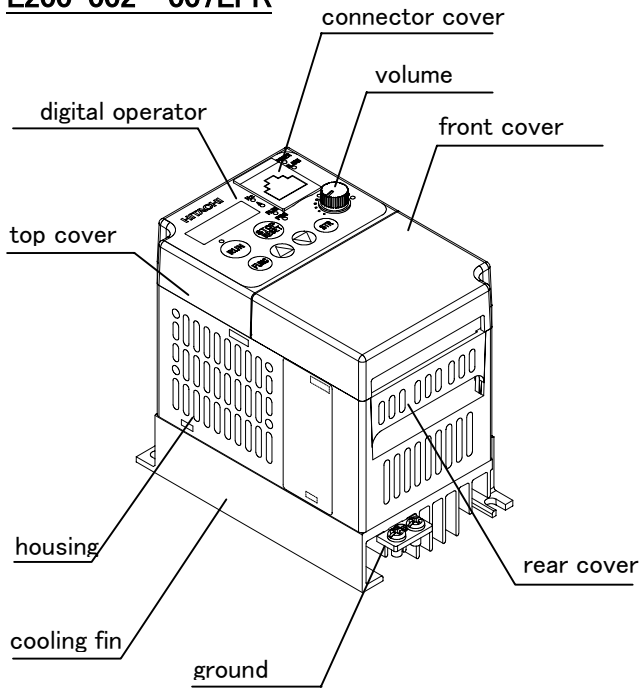

**L200-015~037LFR  
L200-004~037HFR**

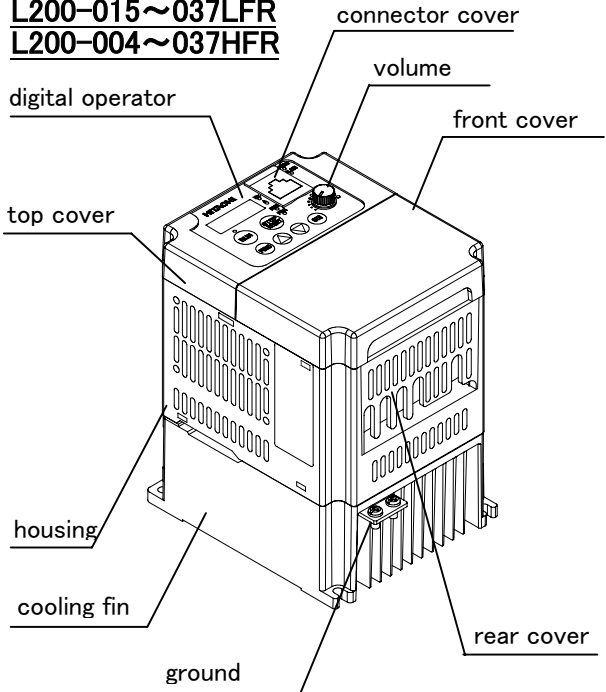

The front cover can be removed without any instruments. When you remove the front cover, you can set the mode switch and set wire at the control-terminal, the main-terminal and the intelligent relay, output terminal.

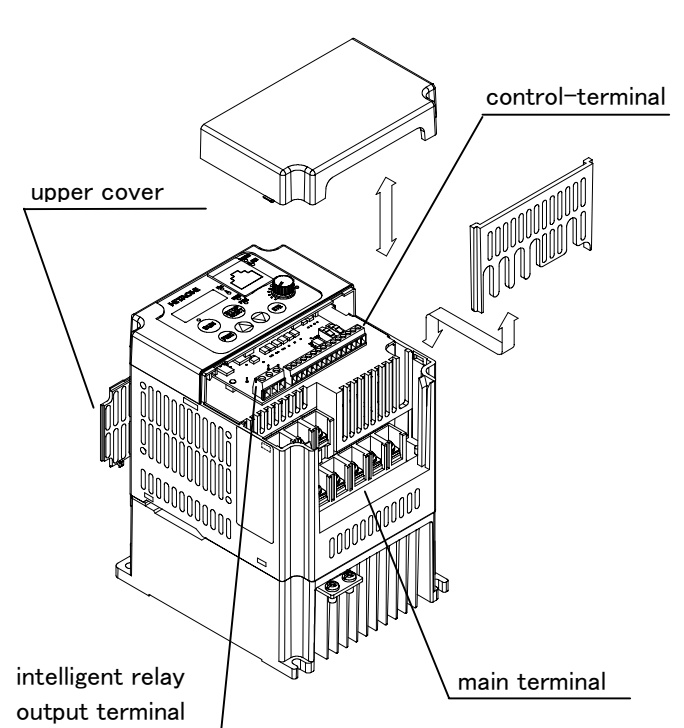
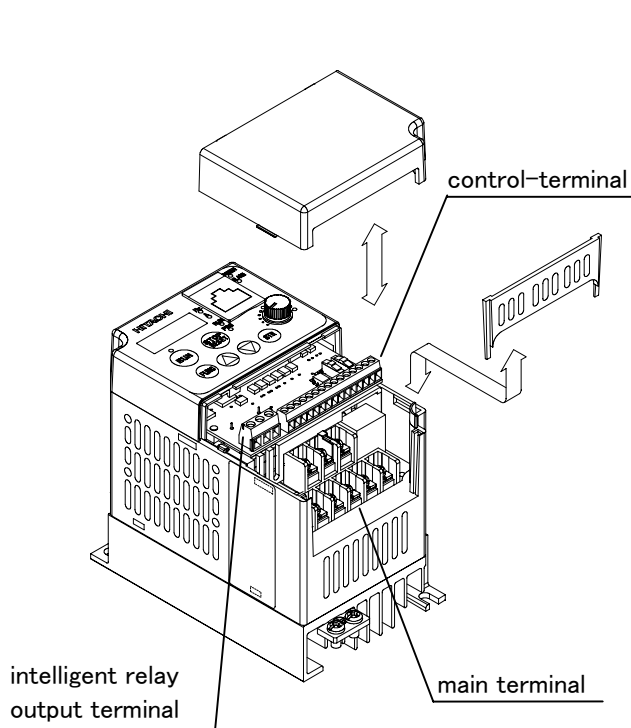

**Note:** The upper cover is for maintenance. Please do not remove.

L200-055~075LFR  
L200-055~075HFR

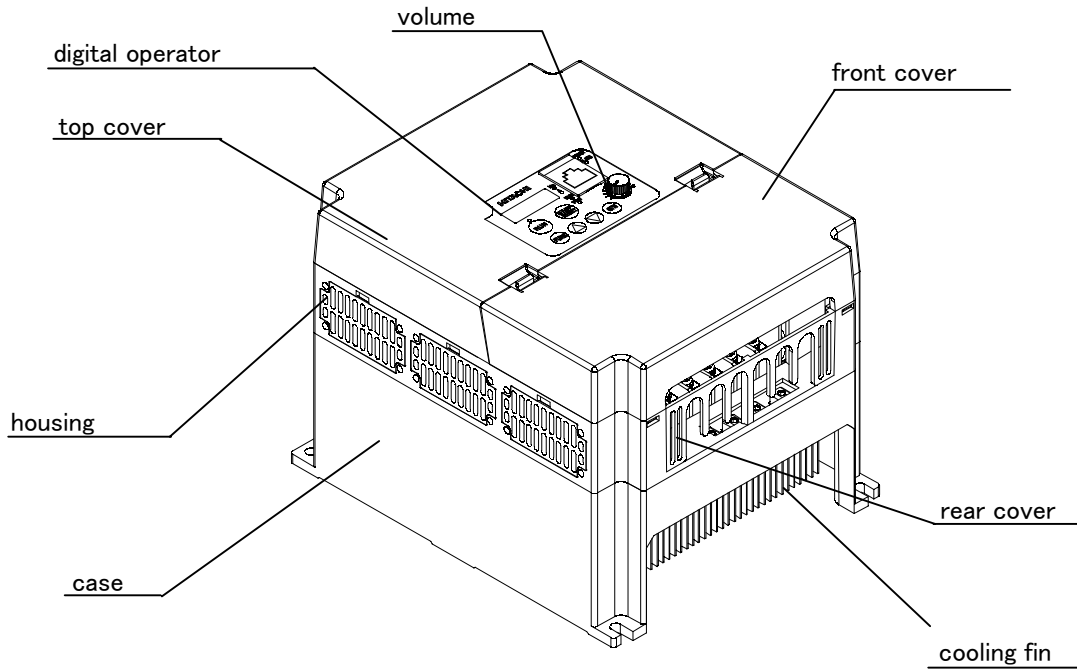

The front cover can be removed without any instruments. When you remove the front cover, you can set the mode switch and set wire at the control-terminal, the main-terminal and the intelligent relay output terminal.

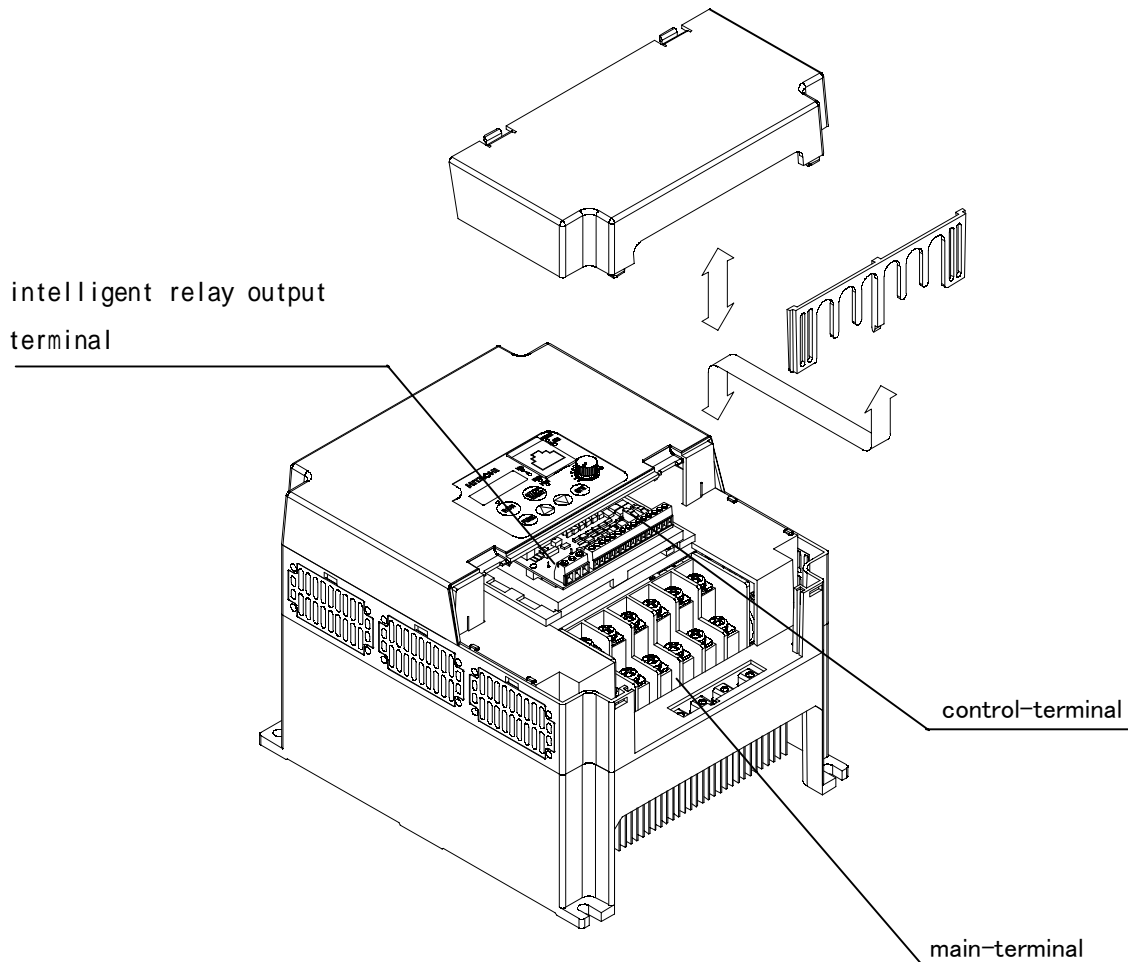

The way to open the connector cover

communication connector

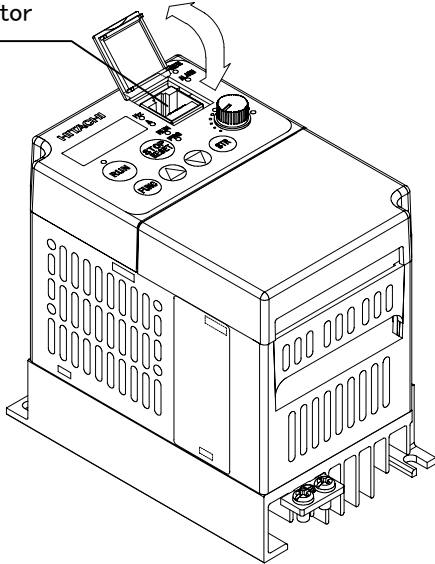

L200-002~007LFR type

Removing the volume

volume

The volume can be removed

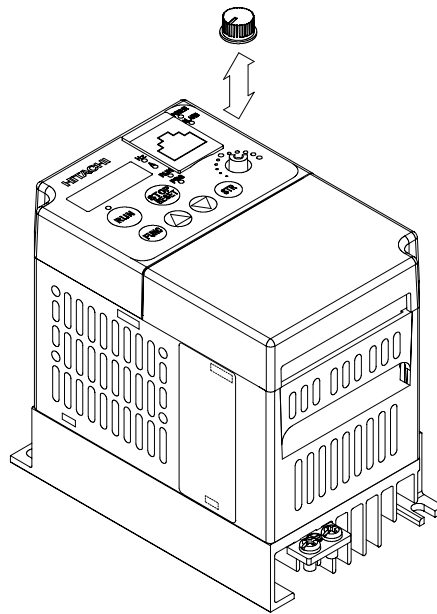

L200-002~007LFR type

Items inside frontcover

L200-002~007LFR type

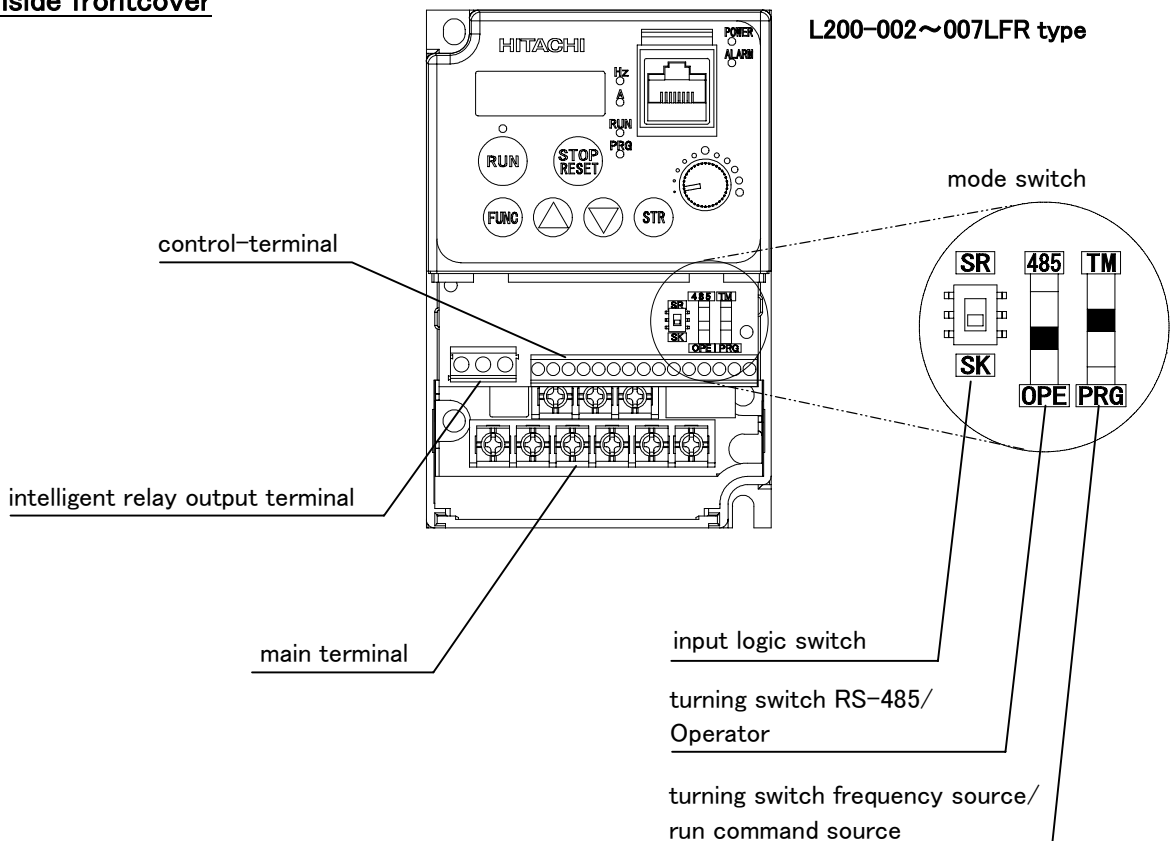

## Appearance

The appearance of SJ200 follows below.

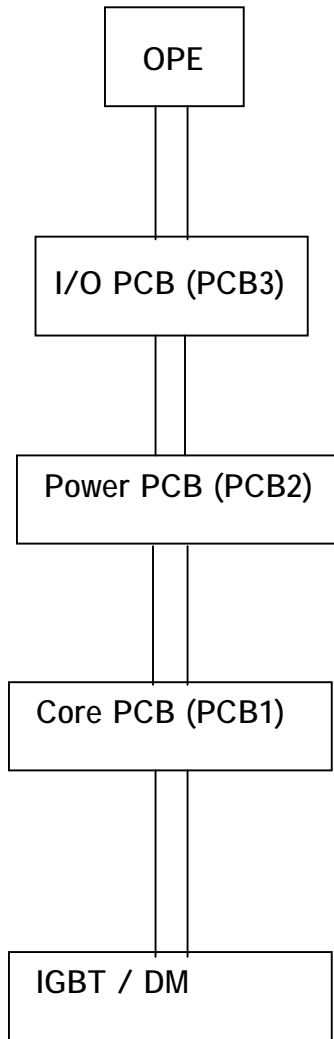

OPE is a control unit.  
Formally OPE is attached to SJ200.  
But another OPE can be used optionally.

This part is a logic circuit.  
It has a microcomputer,  
which does calculation of the  
intelligent input, output, communication task  
and so on

This part is a power circuit.  
It has a translator

This part is a core circuit.  
It has a microcomputer , which manages INV main  
function.

IGBT / DM. is a transistor unit for outputting to the  
motor. It depends on the capacity and the voltage class  
whether IGBT or DM is used.



### Inverter Specifications Label

The Hitachi SJ200 inverters have product labels located on the right side of the housing, as pictured below. Be sure to verify that the specifications on the labels match your power source, motor, and application safety requirements.

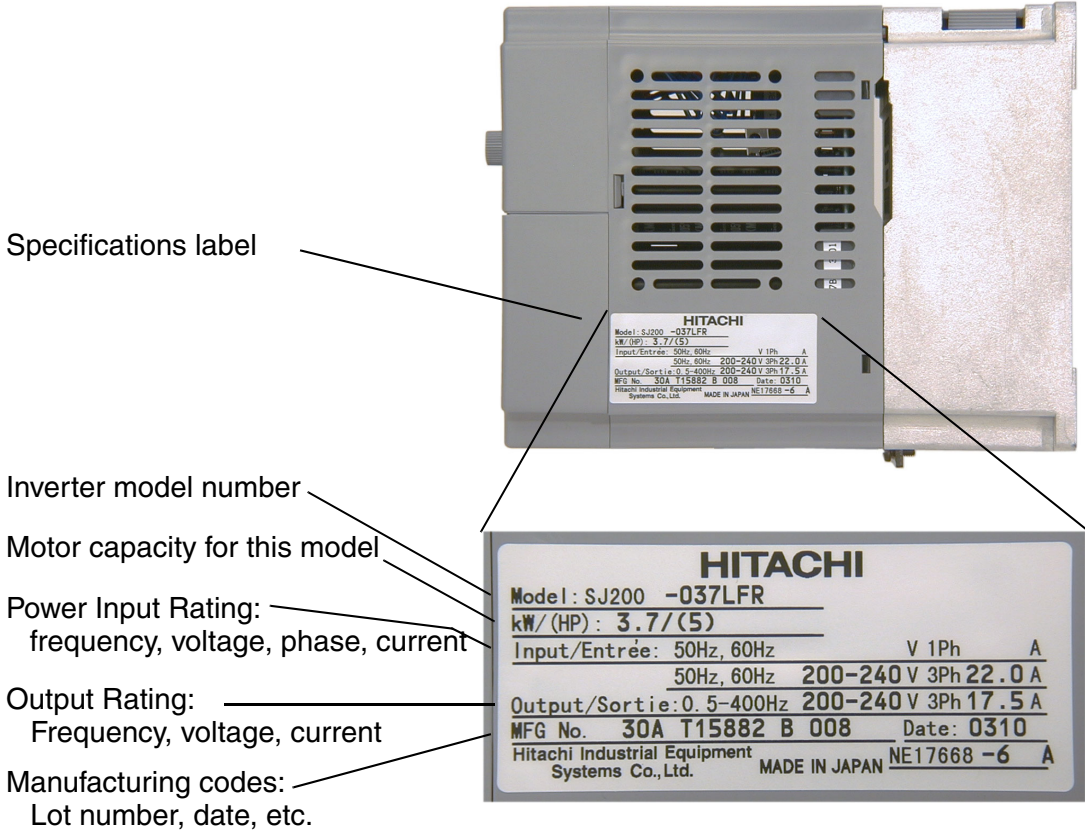

### Model Number Convention

The model number for a specific inverter contains useful information about its operating characteristics. Refer to the model number legend below:

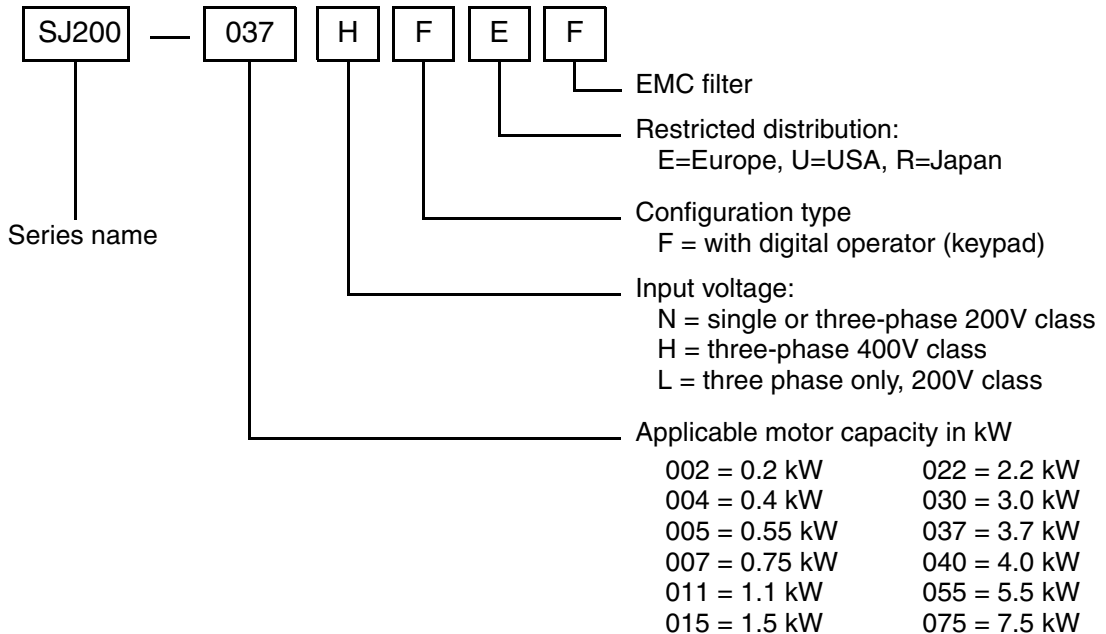

# Orientation to Inverter Features

## Unpacking and Inspection

Please take a few moments to unpack your new SJ200 inverter and perform these steps:

1. Look for any damage that may have occurred during shipping.
2. Verify the contents of the box include:
  - a. One SJ200 inverter
  - b. One Instruction Manual
  - c. One SJ200 Quick Reference Guide
3. Inspect the specifications label on the side of the inverter. Make sure it matches the product part number you ordered.

## Main Physical Features

The SJ200 Series inverters vary in size according to the current output rating and motor size for each model number. All feature the same basic keypad and connector interface for consistent ease of use. The inverter construction has a heat sink at the back of the housing. The larger models include a fan(s) to enhance heat sink performance. The mounting holes are pre-drilled in the heat sink for your convenience. Smaller models have two mounting holes, while larger ones have four. Be sure to use all the mounting holes provided.

Two chassis GND screws are located on the metal tab on the heat sink at the bottom of the inverter. Never touch the heat sink during or just after operation; it can be very hot.

The electronics housing and front panel are built onto the front of the heat sink.

**Inverter Keypad** - The inverter uses a digital operator interface, or keypad. The four-digit display can show a variety of performance parameters. LEDs indicate whether the display units are Hertz or Amperes. Other LEDs indicate Power (external), and Run/Stop Mode and Program/Monitor Mode status. Membrane keys Run and Stop/Reset, and an output frequency potentiometer (speed setting knob) control motor operation. The FUNC.,  $\Delta$ , and  $\nabla$  keys allow an operator to navigate to the inverter's functions and parameter values. The Store key is used when changing a setting.



\*Keypad doesn't display when it is connected badly.

## Inverter Keypad

**Keypad Removal** - The SJ200 has a removable keypad. To remove the keypad, locate the retention latch as shown to the right. Press downward on the latch, while gently pulling toward you. The keypad will tilt forward, as two retaining tabs at the bottom edge of the keypad also hold it in place. Then remove the keypad from the keypad bay.

**\*Caution** - Do not remove keypad when the power is on.



**Internal LED Indicators / Communications Connector** - Refer to the illustration below. After removing the keypad, the internal LED viewing window will be visible. These LEDs indicate status for your convenience when the keypad is remotely mounted and you are nearer to the inverter location.

The RJ45 connection consists of two parts. The clear plastic RJ45 modular interconnect makes the connection between the inverter and the keypad. It is easily removed to allow you to plug a communications cable into the modular connector.

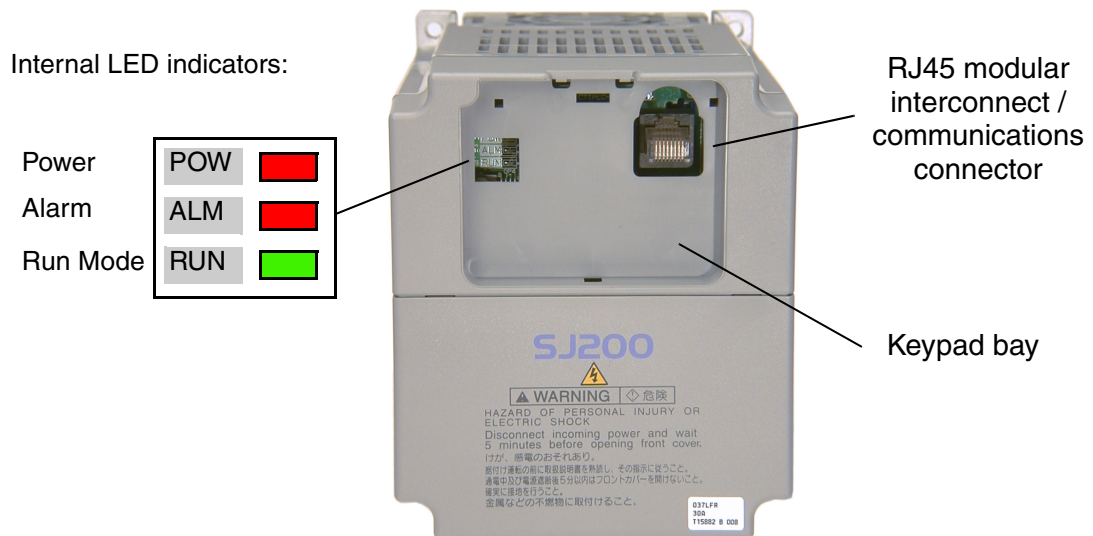

**Installing the Keypad** - Follow these steps:

1. Remember to install the RJ45 modular interconnect. Otherwise, there will be no connection to the keypad.
2. Set the bottom edge of the keypad into the inverter keypad bay.
3. Tilt the top edge of the keypad forward. If it stops before seating firmly, **DO NOT** force the keypad. You may need to adjust the end RJ45 modular connector slightly (upward or downward). Then seat the keypad.
4. Make sure the retention latch clicks into place on the inverter housing top edge. Otherwise, vibration may cause the keypad to loosen in the future.

## Front Housing Cover

**Housing Cover Removal** - The front housing cover is held in place by two pairs of tabs. Since these are hidden from view, it is good to become familiar with their locations *before* attempting to remove the cover. The figure below shows a typical housing cover in upside-down position to reveal the tabs. The two locking tabs are the ones which you will need to press to remove the cover. The two hinging tabs will allow the cover to tilt open once the unlocking tabs are released.

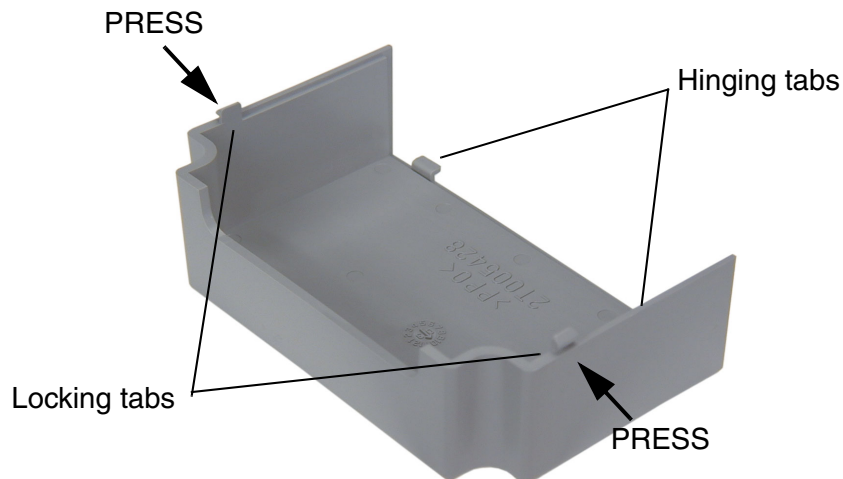

The figure below shows the procedure for removing the housing cover. While pressing inward on the housing, it is helpful to wiggle the cover side-to-side in order to release the locking tabs. **DO NOT** force the cover open; it is possible to break a tab in this way.

1. Press inward on both sides.

2. Tilt upward after both locking tabs are free.

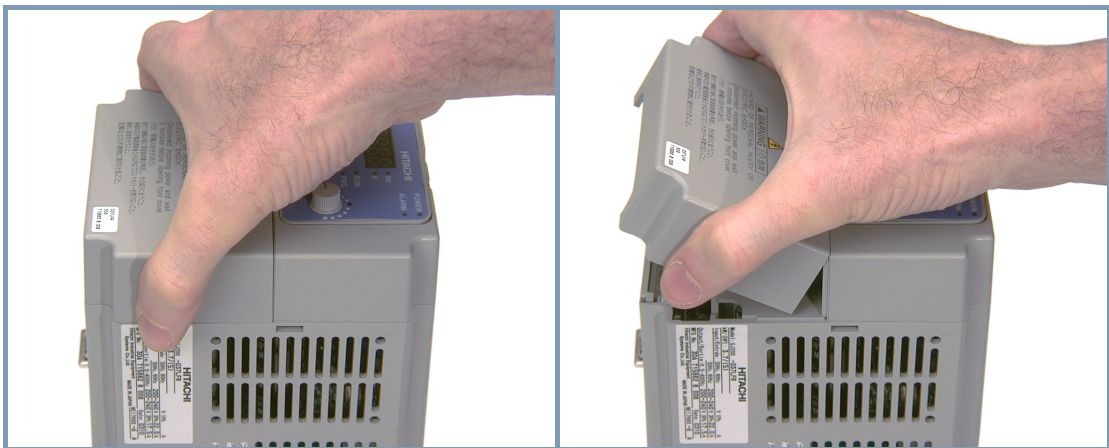



## Removing the Cover (Slide type)

1. Press downward on the cover at the two areas indicated to release the retaining tabs.
2. Slide the cover forward and away from the keypad until the top edge of the cover reaches the notch in the inverter chassis.
3. Lift the cover upward to remove it.

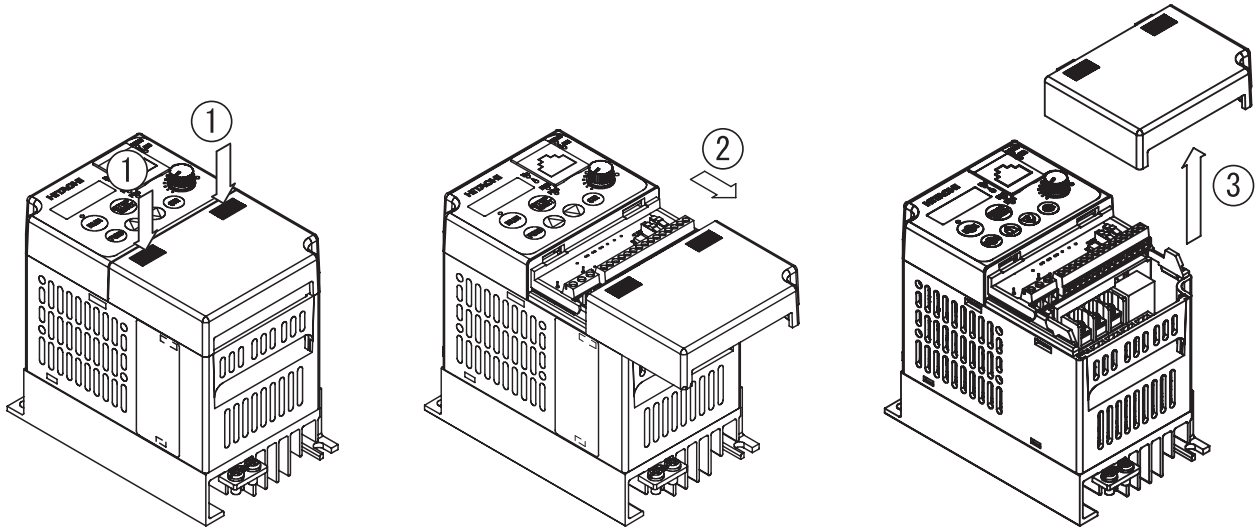

## Installing the Cover (Slide type)

1. Align the tabs on the front housing cover with the notch on each edge of the inverter chassis. Then lower the cover into position.
2. Slide the cover toward the keypad, keeping it flush against the inverter chassis. Continue until the cover latches into place.

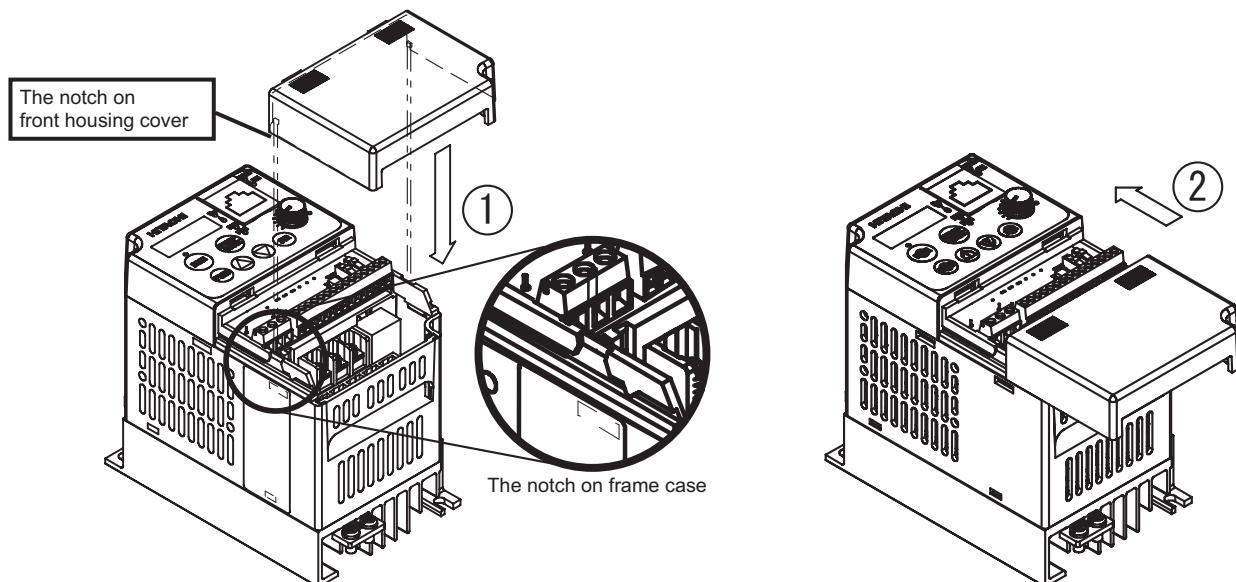

Note: The example inverter in the diagrams is model L200-004LFU. The cover removal or installation method is the same for the other models.

**WARNING:** Be sure to turn off the power supply and wait 10 minutes before you remove the front housing cover. Otherwise, there is a shock hazard.

**Logic Connector Locations** - After removing the front housing cover, take a moment to become familiar with the connectors, as shown below.

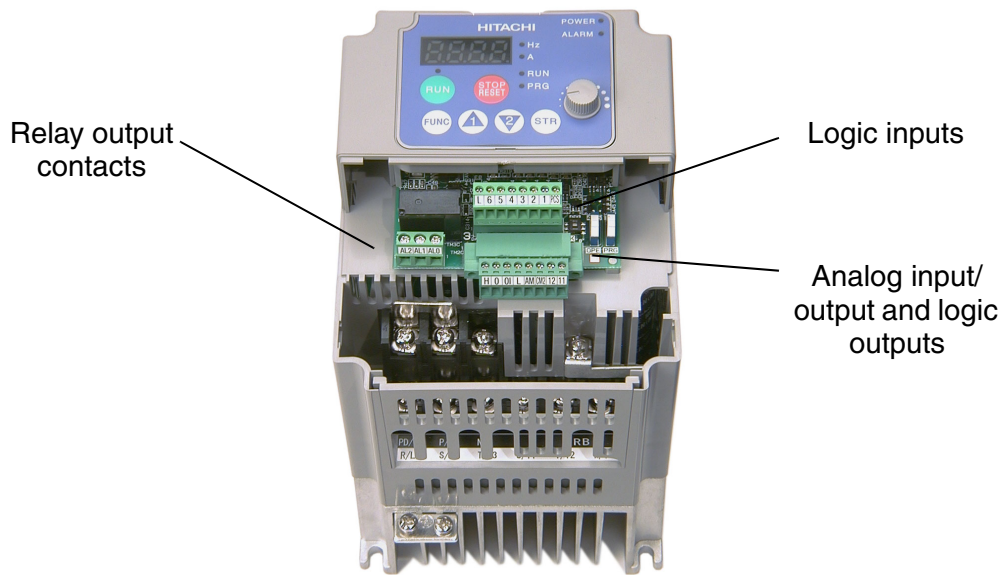

**Logic Connector Removal/Replacement** - The two 8-position main logic connectors are removable from the circuit board to make testing or service more convenient. Note that the relay output connector is not removable, as it must carry higher currents and provide high integrity for alarm conditions. The alarm circuit may carry hazardous live voltages even when the main power to the inverter is OFF. So, never directly touch any terminal or circuit component.

The logic input connector (top connector) can be removed by pulling gently upward as shown (below left). DO NOT force the connector, as damage to the circuit board may occur. Try gently shifting the connector side-to-side while pulling, if having difficulty.

The analog input/output and logic output connector (bottom connector) **has retention screws**. DO NOT attempt to remove the connector before loosening the screws. As the figure shows (below right), use a small Phillips screwdriver to loosen the screw at each end. The connector can be pulled forward easily after the screws are removed.

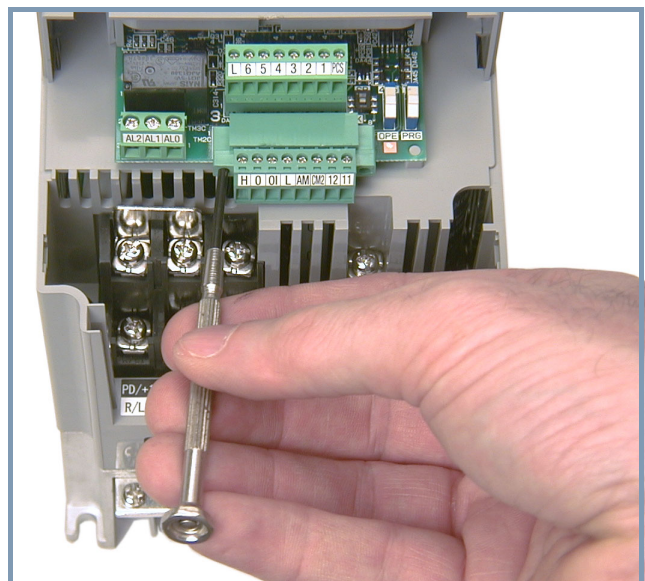
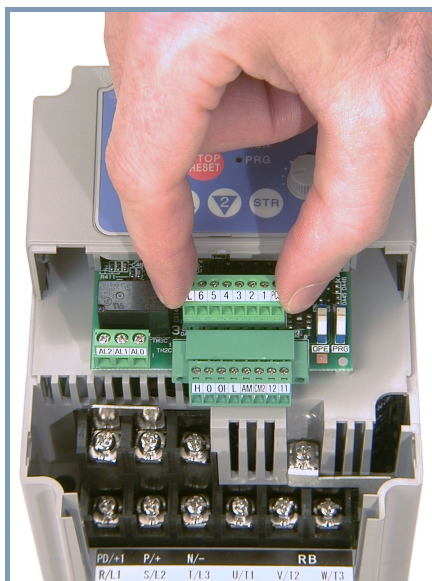

**Power Wiring Access** - First, ensure no power source of any kind is connected to the inverter. If power has been connected, wait five minutes after powerdown and verify the Power LED is OFF to proceed. After removing the front housing cover, the housing partition that covers the power wiring exit will be able to slide upward as shown to the right.

Notice the four wire exit slots (on larger model inverters) in the housing partition. This helps keep the power wiring (to the left) separate from signal-level logic or analog wiring (to the right).

Remove the housing partition and as shown as set it aside in a secure place while wiring. Never operate the inverter drive with the partition removed or the front housing cover removed.



The power input and motor 3-phase wiring connect to the lower row of terminals. The upper row of power terminals connect to optional dynamic braking components.

The following sections in this chapter will describe the system design and guide you through a step-by-step installation process. After the section on wiring, this chapter will show how to use the front panel keys to access functions and edit parameters.

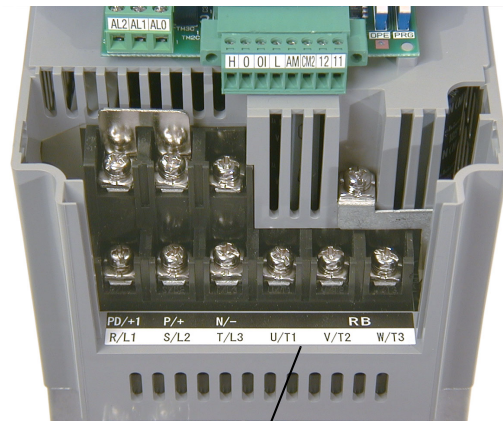

Power and motor connector terminals

**OPE / 485 DIP Switch -**

The difference between OPE-S and OPE-Smini is the short-circuit inside the connector.  
If you set 485-side OPE-S,SRW says "----"(communication error)  
But OPE-Smini works properly.

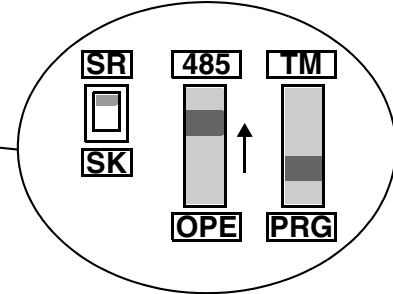
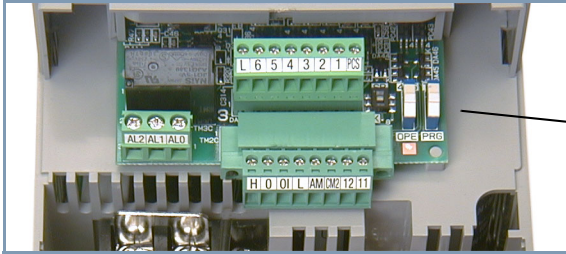



# Introduction

This section lists the user-programmable parameters for the SJ200 series inverters and the default values for European and U.S. product types. The right-most column of the tables is blank, so you can record values you have changed from the default. This involves just a few parameters for most applications. This section presents the parameters in a format oriented toward the keypad on the inverter.

## Parameter Settings for Keypad Entry

SJ200 series inverters provide many functions and parameters that can be configured by the user. We recommend that you record all parameters that have been edited, in order to help in troubleshooting or recovery from a loss of parameter data.

Inverter model	SJ200		}	This information is printed on the specification label located on the right side of the inverter.
MFG. No.				

### Main Profile Parameters

“F” Group Parameters		Default Setting		User Setting
Func. Code	Name	-FE (Europe)	-FU (USA)	
F001	Output frequency setting	0.0	0.0	
F002	Acceleration (1) time setting	10.0	10.0	
F202	Acceleration (1) time setting, 2nd motor	10.0	10.0	
F003	Deceleration (1) time setting	10.0	10.0	
F203	Deceleration (1) time setting, 2nd motor	10.0	10.0	
F004	Keypad Run key routing	00	00	

## Standard Functions

“A” Group Parameters		Default Setting		User Setting
Func. Code	Name	-FEF (EU)	-FU (USA)	
A001	Frequency source setting	01	00	
A002	Run command source setting	01	02	
A003	Base frequency setting	50.0	60.0	
A203	Base frequency setting, 2nd motor	50.0	60.0	
A004	Maximum frequency setting	50.0	60.0	
A204	Maximum frequency setting, 2nd motor	50.0	60.0	
A005	[AT] selection	00	00	
A011	O-L input active range start frequency	0.0	0.0	
A012	O-L input active range end frequency	0.0	0.0	
A013	O-L input active range start voltage	0.0	0.0	
A014	O-L input active range end voltage	100.	100.	
A015	O-L input start frequency enable	01	01	
A016	External frequency filter time constant	2.	8.	
A020	Multi-speed 0 setting	0.0	0.0	
A220	Multi-speed 0 setting, 2nd motor	0.0	0.0	
A021	Multi-speed 1 setting	0.0	0.0	
A022	Multi-speed 2 setting	0.0	0.0	
A023	Multi-speed 3 setting	0.0	0.0	
A024	Multi-speed 4 setting	0.0	0.0	
A025	Multi-speed 5 setting	0.0	0.0	
A026	Multi-speed 6 setting	0.0	0.0	
A027	Multi-speed 7 setting	0.0	0.0	
A028	Multi-speed 8 setting	0.0	0.0	
A029	Multi-speed 9 setting	0.0	0.0	
A030	Multi-speed 10 setting	0.0	0.0	
A031	Multi-speed 11 setting	0.0	0.0	

“A” Group Parameters		Default Setting		User Setting
Func. Code	Name	-FEF (EU)	-FU (USA)	
A032	Multi-speed 12 setting	0.0	0.0	
A033	Multi-speed 13 setting	0.0	0.0	
A034	Multi-speed 14 setting	0.0	0.0	
A035	Multi-speed 15 setting	0.0	0.0	
A038	Jog frequency setting	1.00	1.00	
A039	Jog stop mode	00	00	
A042	Manual torque boost value	5.0	5.0	
A242	Manual torque boost value, 2nd motor	0.0	0.0	
A043	Manual torque boost frequency adjustment	3.0	3.0	
A243	Manual torque boost frequency adjustment, 2nd motor	0.0	0.0	
A044	V/f characteristic curve selection	02	02	
A244	V/f characteristic curve selection, 2nd motor	02	02	
A045	V/f gain setting	100.	100.	
A046	iSLV voltage compensation gain	100	100	
A246	iSLV voltage compensation gain, 2nd motor	100	100	
A047	iSLV slip compensation gain	100	100	
A247	iSLV slip compensation gain, 2nd motor	100	100	
A051	DC braking enable	00	00	
A052	DC braking frequency setting	0.5	0.5	
A053	DC braking wait time	0.0	0.0	
A054	DC braking force for deceleration	0	0	
A055	DC braking time for deceleration	0.0	0.0	
A056	DC braking / edge or level detection for [DB] input	01	01	
A061	Frequency upper limit setting	0.0	0.0	
A261	Frequency upper limit setting, 2nd motor	0.0	0.0	

“A” Group Parameters		Default Setting		User Setting
Func. Code	Name	-FEF (EU)	-FU (USA)	
A062	Frequency lower limit setting	0.0	0.0	
A262	Frequency lower limit setting, 2nd motor	0.0	0.0	
A063, A065, A067	Jump (center) frequency setting	0.0	0.0	
A064, A066, A068	Jump (hysteresis) frequency width setting	0.5	0.5	
A071	PID Enable	00	00	
A072	PID proportional gain	1.0	1.0	
A073	PID integral time constant	1.0	1.0	
A074	PID derivative time constant	0.0	0.0	
A075	PV scale conversion	1.00	1.00	
A076	PV source setting	00	00	
A077	Reverse PID action	00	00	
A078	PID output limit	0.0	0.0	
A081	AVR function select	00	00	
A082	AVR voltage select	230/400	230/460	
A092	Acceleration (2) time settin	15.00	15.00	
A292	Acceleration (2) time setting, (2nd motor)	15.00	15.00	
A093	Deceleration (2) time setting	15.00	15.00	
A293	Deceleration (2) time setting, (2nd motor)	15.00	15.00	
A094	Select method to switch to Acc2/Dec2 profile	00	00	
A294	Select method to switch to Acc2/Dec2 profile, 2nd motor	00	00	
A095	Acc1 to Acc2 frequency transition point	0.0	0.0	
A295	Acc1 to Acc2 frequency transition point, 2nd motor	0.0	0.0	
A096	Dec1 to Dec2 frequency transition point	0.0	0.0	

“A” Group Parameters		Default Setting		User Setting
Func. Code	Name	-FEF (EU)	-FU (USA)	
A296	Dec1 to Dec2 frequency transition point, 2nd motor	0.0	0.0	
A097	Acceleration curve selection	00	00	
A098	Deceleration curve selection	00	00	
A101	[OI]–[L] input active range start frequency	0.0	0.0	
A102	[OI]–[L] input active range end frequency	0.0	0.0	
A103	[OI]–[L] input active range start current	0.0	0.0	
A104	[OI]–[L] input active range end current	100.	100.	
A105	[OI]–[L] input start frequency enable	01	01	
A141	A input select for calculate function	02	02	
A142	B input select for calculate function	03	03	
A143	Calculation symbol	00	00	
A145	ADD frequency	0.0	0.0	
A146	ADD direction select	00	00	

## Fine Tuning Functions

“B” Group Parameters		Default Setting		User Setting
Func. Code	Name	-FEF (EU)	-FU (USA)	
B001	Selection of automatic restart mode	00	00	
B002	Allowable under-voltage power failure time	1.0	1.0	
B003	Retry wait time before motor restart	1.0	1.0	
B004	Instantaneous power failure / under-voltage trip alarm enable	00	00	
B005	Number of restarts on power failure / under-voltage trip events	00	00	
B012	Level of electronic thermal setting	Rated current for each inverter	Rated current for each inverter	
B212	Level of electronic thermal setting, 2nd motor	Rated current for each inverter	Rated current for each inverter	
B013	Electronic thermal characteristic	01	01	
B213	Electronic thermal characteristic, 2nd motor	01	01	
B021	Overload restriction operation mode	01	01	
B022	Overload restriction setting	Rated current x 1.5	Rated current x 1.5	
B023	Deceleration rate at overload restriction	1.0	30.0	
B031	Software lock mode selection	01	01	
B080	[AM] analog signal gain	100.	100.	
B082	Start frequency adjustment	0.5	0.5	
B083	Carrier frequency setting	5.0	5.0	
B084	Initialization mode (parameters or trip history)	00	00	
B085	Country code for initialization	01	02	
B086	Frequency scaling conversion factor	1.0	1.0	

“B” Group Parameters		Default Setting		User Setting
Func. Code	Name	-FEF (EU)	-FU (USA)	
B087	STOP key enable	00	00	
B088	Restart mode after FRS	00	00	
B090	Dynamic braking usage ratio	0.0	0.0	
B091	Stop mode selection	00	00	
B092	Cooling fan control	00	00	
B095	Dynamic braking control	00	00	
B096	Dynamic braking activation level	360/720	360/720	
B130	Over-voltage LADSTOP enable	00	00	
B140	Over-current trip suppression	00	00	
B150	Carrier mode	00	00	

## Intelligent Terminal Functions

“C” Group Parameters		Default Setting		User Setting
Func. Code	Name	-FEF (EU)	-FU (USA)	
C001	Terminal [1] function	00	00	
C002	Terminal [2] function	01	01	
C003	Terminal [3] function	02	16	
C004	Terminal [4] function	03	13	
C005	Terminal [5] function	18	09	
C006	Terminal [6] function	09	18	
C011	Terminal [1] active state	00	00	
C012	Terminal [2] active state	00	00	
C013	Terminal [3] active state	00	00	
C014	Terminal [4] active state	00	01	
C015	Terminal [5] active state	00	00	
C016	Terminal [6] active state	00	00	
C021	Terminal [11] function	01	01	
C022	Terminal [12] function	00	00	
C026	Alarm relay terminal function	05	05	
C028	[AM] signal selection	00	00	
C031	Terminal [11] active state	00	00	
C032	Terminal [12] active state	00	00	
C036	Alarm relay active state	01	01	
C041	Overload level setting	Inverter rated current	Inverter rated current	
C042	Frequency arrival setting for acceleration	0.0	0.0	
C043	Arrival frequency setting for deceleration	0.0	0.0	
C044	PID deviation level setting	3.0	3.0	
C052	PID FBV function high limit	100.0	100.0	
C053	PID FBV function low limit	0.0	0.0	
C071	Communication speed selection	06	04	
C072	Node allocation	1.	1.	
C074	Communication parity selection	00	00	



“C” Group Parameters		Default Setting		User Setting
Func. Code	Name	-FEF (EU)	-FU (USA)	
C075	Communication stop bit selection	1	1	
C076	Communication error select	02	02	
C077	Communication error time-out	0.00	0.00	
C078	Communication wait time	0.	0.	
C081	O input span calibration	100.0	100.0	
C082	OI input span calibration	100.0	100.0	
C085	Thermistor input tuning	100.0	100.0	
C086	[AM] terminal offset tuning	0.0	0.0	
C091	Debug mode enable	00	00	
C101	Up/Down memory mode selection	00	00	
C102	Reset selection	00	00	
C141	Input A select for logic output	00	00	
C142	Input B select for logic output	01	01	
C143	Logic function select	00	00	
C144	Terminal [11] ON delay	0.0	0.0	
C145	Terminal [11] OFF delay	0.0	0.0	
C146	Terminal [12] ON delay	0.0	0.0	
C147	Terminal [12] OFF delay	0.0	0.0	
C148	Output relay ON delay	0.0	0.0	
C149	Output relay OFF delay	0.0	0.0	

## Motor Constants Functions

“H” Group Parameters		Default Setting		User Setting
Func. Code	Name	-FEF (EU)	-FU (USA)	
H003	Motor capacity	Specified by the inverter capacity	Specified by the inverter capacity	
H203	Motor capacity, 2nd setting	Specified by the inverter capacity	Specified by the inverter capacity	
H004	Motor poles setting	4	4	
H204	Motor poles setting, 2nd motor	4	4	
H006	Motor stabilization constant	100	100	
H206	Motor stabilization constant, 2nd motor	100	100	
H007	Motor voltage select	Specified by the inverter voltage	Specified by the inverter voltage	
H207	Motor voltage select, 2nd motor	Specified by the inverter voltage	Specified by the inverter voltage	

# Troubleshooting

## Safety Messages

Please read the following safety messages before troubleshooting or performing maintenance on the inverter and motor system.



---

**WARNING:** Wait at least five (5) minutes after turning OFF the input power supply before performing maintenance or an inspection. Otherwise, there is the danger of electric shock.

---



---

**WARNING:** Make sure that only qualified personnel will perform maintenance, inspection, and part replacement. Before starting to work, remove any metallic objects from your person (wristwatch, bracelet, etc.). Be sure to use tools with insulated handles. Otherwise, there is a danger of electric shock and/or injury to personnel.

---



---

**WARNING:** Never remove connectors by pulling on its wire leads (wires for cooling fan and logic P.C.board). Otherwise, there is a danger of fire due to wire breakage and/or injury to personnel.

---

## General Precautions and Notes

- Always keep the unit clean so that dust or other foreign matter does not enter the inverter.
- Take special care in regard to breaking wires or making connection mistakes.
- Firmly connect terminals and connectors.
- Keep electronic equipment away from moisture and oil. Dust, steel filings and other foreign matter can damage insulation, causing unexpected accidents, so take special care.

## Inspection Items

This chapter provides instructions or checklists for these inspection items:

- Daily inspection
- Periodic inspection (approximately once a year)
- Insulation resistance test

## Troubleshooting Tips

The table below lists typical symptoms and the corresponding solution(s).

Symptom/condition		Probable Cause	Solution
The motor will not run.	The inverter outputs [U], [V], [W] are not supplying voltage.	<ul style="list-style-type: none"> <li>Is the frequency command source A001 parameter setting correct?</li> <li>Is the Run command source A002 parameter setting correct?</li> </ul>	<ul style="list-style-type: none"> <li>Make sure the parameter setting A001 is correct.</li> <li>Make sure the parameter setting A002 is correct.</li> </ul>
		<ul style="list-style-type: none"> <li>Is power being supplied to terminals [L1], [L2], and [L3/N]? If so, the POWER lamp should be ON.</li> </ul>	<ul style="list-style-type: none"> <li>Check terminals [L1], [L2], and [L3/N], then [U/T1], [V/T2], and [W/T3].</li> <li>Turn ON the power supply or check fuses.</li> </ul>
		<ul style="list-style-type: none"> <li>Is there an error code <b>EXX</b> displayed?</li> </ul>	<ul style="list-style-type: none"> <li>Press the Func. key and determine the error type. Eliminate the error cause, then clear the error (Reset).</li> </ul>
		<ul style="list-style-type: none"> <li>Are the signals to the intelligent input terminals correct?</li> <li>Is the Run Command active?</li> <li>Is the [FW] terminal (or [RV]) connected to [P24] (via switch, etc.)</li> </ul>	<ul style="list-style-type: none"> <li>Verify the terminal functions for C001 – C006 are correct.</li> <li>Turn ON Run Command enable.</li> <li>Supply 24V to {FW} or [RV] terminal, if configured.</li> </ul>
		<ul style="list-style-type: none"> <li>Has the frequency setting for F001 been set greater than zero?</li> <li>Are the control circuit terminals [H], [O], and [L] connected to the potentiometer?</li> </ul>	<ul style="list-style-type: none"> <li>Set the parameter for F001 to a safe, non-zero value.</li> <li>If the potentiometer is the frequency setting source, verify voltage at [O] &gt; 0V.</li> </ul>
		<ul style="list-style-type: none"> <li>Is the RS (reset) function or FRS (free-run stop) function ON?</li> </ul>	<ul style="list-style-type: none"> <li>Turn OFF the command(s).</li> </ul>
	Inverter outputs [U], [V], [W] are supplying voltage.	<ul style="list-style-type: none"> <li>Is the motor load too heavy?</li> </ul>	<ul style="list-style-type: none"> <li>Reduce load, and test the motor independently.</li> </ul>
The optional remote operator is used (SRW).	<ul style="list-style-type: none"> <li>Are the operational settings between the remote operator and the inverter unit correct?</li> </ul>	<ul style="list-style-type: none"> <li>Check the operator type setting.</li> </ul>	
The direction of the motor is reversed.	<ul style="list-style-type: none"> <li>Are the connections of output terminals [U/T1], [V/T2], and [W/T3] correct?</li> <li>Is the phase sequence of the motor forward or reverse with respect to [U/T1], [V/T2], and [W/T3]?</li> </ul>	<ul style="list-style-type: none"> <li>Make connections according to the phase sequence of the motor. In general: FWD = U-V-W, and REV=U-W-V.</li> </ul>	
	<ul style="list-style-type: none"> <li>Are the control terminals [FW] and [RV] wired correctly?</li> <li>Is parameter F004 properly set?</li> </ul>	<ul style="list-style-type: none"> <li>Use terminal [FW] for forward, and [RV] for reverse.</li> <li>Set motor direction in F004.</li> </ul>	

Symptom/condition		Probable Cause	Solution
The motor speed will not reach the target frequency (desired speed).		<ul style="list-style-type: none"> <li>• If using the analog input, is the current or voltage at [O] or [OI]?</li> </ul>	<ul style="list-style-type: none"> <li>• Check the wiring.</li> <li>• Check the potentiometer or signal generating device.</li> </ul>
		<ul style="list-style-type: none"> <li>• Is the load too heavy?</li> </ul>	<ul style="list-style-type: none"> <li>• Reduce the load.</li> <li>• Heavy loads activate the overload restriction feature (reduces output as needed).</li> </ul>
		<ul style="list-style-type: none"> <li>• Is the inverter internally limiting the output frequency?</li> </ul>	<ul style="list-style-type: none"> <li>• Check max frequency setting (A004)</li> <li>• Check frequency upper limit setting (A061)</li> </ul>
The rotation is unstable.		<ul style="list-style-type: none"> <li>• Is the load fluctuation too great?</li> <li>• Is the supply voltage unstable?</li> <li>• Is the problem occurring at a particular frequency?</li> </ul>	<ul style="list-style-type: none"> <li>• Increase the motor capacity (both inverter and motor).</li> <li>• Fix power supply problem.</li> <li>• Change the output frequency slightly, or use the jump frequency setting to skip the problem frequency.</li> </ul>
The RPM of the motor does not match the inverter output frequency setting.		<ul style="list-style-type: none"> <li>• Is the maximum frequency setting A004 correct?</li> <li>• Does the monitor function D001 display the expected output frequency?</li> </ul>	<ul style="list-style-type: none"> <li>• Verify the V/f settings match motor specifications.</li> <li>• Make sure all scaling (such as A011 to A014) is properly set.</li> </ul>
Inverter data is not correct.	No downloads have occurred.	<ul style="list-style-type: none"> <li>• Was power turned OFF after a parameter edit but before pressing the Store key?</li> <li>• Edits to data are permanently stored at power down. Was the time from power OFF to power ON less than six seconds?</li> </ul>	<ul style="list-style-type: none"> <li>• Edit the data and press the Store key once.</li> <li>• Wait six seconds or more before turning power OFF after editing data.</li> </ul>
	A download to the inverter was attempted.	<ul style="list-style-type: none"> <li>• Was the power turned OFF within six seconds after the display changed from REMT to INV?</li> </ul>	<ul style="list-style-type: none"> <li>• Copy the data to the inverter again, and keep power ON for six seconds or more after copying.</li> </ul>
A parameter will not change after an edit (reverts to old setting).	True for certain parameters	<ul style="list-style-type: none"> <li>• Is the inverter in Run Mode? Some parameters cannot be edited during Run Mode.</li> </ul>	<ul style="list-style-type: none"> <li>• Put inverter in Stop Mode (press the Stop/reset key). Then edit the parameter.</li> </ul>
	True for all parameters	<ul style="list-style-type: none"> <li>• If you're using the [SFT] intelligent input (software lock function)—is the [SFT] input ON?</li> </ul>	<ul style="list-style-type: none"> <li>• Change the state of the SFT input, and check the B031 parameter (SFT mode).</li> </ul>

# Monitoring Trip Events, History, & Conditions

## Fault Detection and Clearing

The microprocessor in the inverter detects a variety of fault conditions and captures the event, recording it in a history table. The inverter output turns OFF, or “trips” similar to the way a circuit breaker trips due to an over-current condition. Most faults occur when the motor is running (refer to the diagram to the right). However, the inverter could have an internal fault and trip in Stop Mode. In either case, you can clear the fault by pressing the Stop/Reset key. Additionally, you can clear the inverter’s cumulative trip history by performing the procedure “Restoring Factory Default Settings” on page 6–8 (setting B084=00 will clear the trip history but leave inverter settings intact).

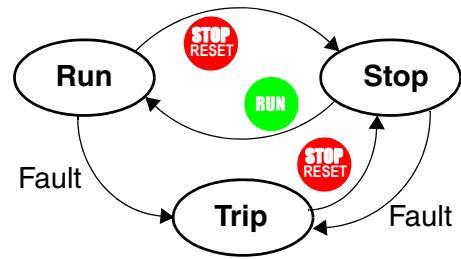

## Error Codes

An error code will appear on the display automatically when a fault causes the inverter to trip. The following table lists the cause associated with the error.

Error Code	Name	Cause(s)
<b>E01</b>	Over current event while at constant speed	The inverter output was short-circuited, or the motor shaft is locked or has a heavy load. These conditions cause excessive current for the inverter, so the inverter output is turned OFF.  The dual-voltage motor is wired incorrectly. If b083 is too high, please reduce the value.
<b>E02</b>	Over current event during deceleration	
<b>E03</b>	Over current event during acceleration	
<b>E04</b>	Over current event during other conditions	
<b>E05</b>	Overload protection	When a motor overload is detected by the electronic thermal function, the inverter trips and turns OFF its output.
<b>E06</b>	Braking resistor overload	When the regenerative braking resistor exceeds the usage time allowance or usage ratio, the inverter trips and turns OFF its output to the motor.
<b>E07</b>	Over voltage protection	When the DC bus voltage exceeds a threshold, due to regenerative energy from the motor.
<b>E08</b>	EEPROM error	When the built-in EEPROM memory has problems due to noise or excessive temperature, the inverter trips and turns OFF its output to the motor.
<b>E09</b>	Under-voltage error	A decrease of internal DC bus voltage below a threshold results in a control circuit fault. This condition can also generate excessive motor heat or cause low torque. The inverter trips and turns OFF its output.

Error Code	Name	Cause(s)
<i>E11</i> <i>E22</i>	CPU error	A malfunction in the built-in CPU has occurred, so the inverter trips and turns OFF its output to the motor.
<i>E12</i>	External trip	A signal on an intelligent input terminal configured as EXT has occurred. The inverter trips and turns OFF the output to the motor.
<i>E13</i>	USP	When the Unattended Start Protection (USP) is enabled, an error occurred when power is applied while a Run signal is present. The inverter trips and does not go into Run Mode until the error is cleared.
<i>E14</i>	Ground fault	The inverter is protected by the detection of ground faults between the inverter output and the motor upon during powerup tests. This feature protects the inverter, and does not protect humans.
<i>E15</i>	Input over-voltage (*)	When the input voltage is higher than the specified value, it is detected 100 seconds after powerup and the inverter trips and turns OFF its output.
<i>E21</i>	Inverter thermal trip	When the inverter internal temperature is above the threshold, the thermal sensor in the inverter module detects the excessive temperature of the power devices and trips, turning the inverter output OFF.
<i>E23</i>	Gate array error	An internal inverter error has occurred in communications between the CPU and gate array IC.
<i>E35</i>	Thermistor	When a thermistor is connected to terminals [6] and [L] and the inverter has sensed the temperature is too high, the inverter trips and turns OFF the output.
<i>E60</i>	Communications error	The inverter's watchdog timer for the communications network has timed out.
<i>- - -</i>	Under-voltage (brown-out) with output shutoff	Due to low input voltage, the inverter turns its output OFF and tries to restart. If it fails to restart, then the alarm trips to record the under-voltage error event.



**NOTE:** If an EEPROM error (E08) occurs, be sure to confirm the parameter data values are still correct. If the power is turned OFF while the [RS] (Reset) intelligent input terminal is ON, an EEPROM error will occur when power is restored.

**Caution:** EXT,PTC trip has a possibility of breaking I/O circuit and breaking EEPROM data

\*:OVSRC(E15) trip level is relatively changed for 200/400V class in 3440(Core) and 3524(I/O) software.

### Trip History and Inverter Status



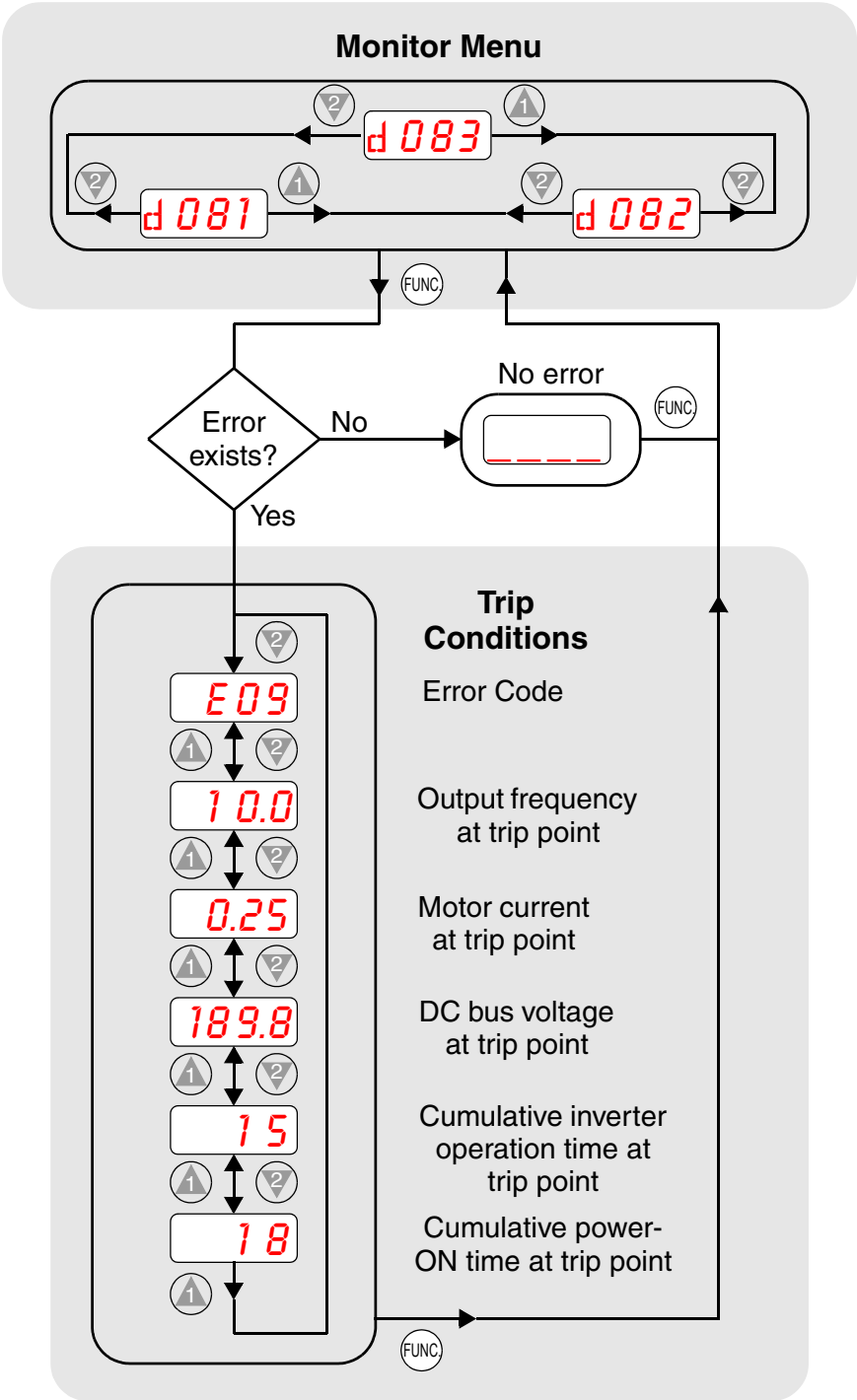















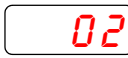



















We recommend that you first find the cause of the fault before clearing it. When a fault occurs, the inverter stores important performance data at the moment of the fault. To access the data, use the monitor functions (Dxxx) and select D081 for details about the present fault (E<sub>n</sub>). The previous two faults are stored in D082 and D083, with D(E<sub>n-1</sub> and E<sub>n-2</sub>). Each error shifts D081–D082 to D082–D083, and writes the new error to D081. The following Monitor Menu map shows how to access the error codes. When fault(s) exist, you can review their details by first selecting the proper function: D081 is the most recent, and D083 is the oldest.



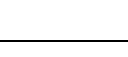

## Restoring Factory Default Settings

You can restore all inverter parameters to the original factory (default) settings for the intended country of use. After initializing the inverter, use the powerup test in Chapter 2 to get the motor running again. To initialize the inverter, follow the steps below.

No.	Action	Display	Func./Parameter
1	Use the  ,  , and  keys to navigate to the “B” Group.		“B” Group selected
2	Press the  key.		First “B” parameter selected
3	Press and hold the  key until ->		Country code for initialization selected
4	Press the  key.		00 = Japan, 01 = Europe, 02 = U.S.
5	Confirm the country code is correct. Do not change it unless you are absolutely sure the power input voltage range and frequency match the country code setting. To change the country code, press  or  to set,  to store.		
6	Press the  key.		Country code for initialization selected
7	Press the  key.		Initialization function selected
8	Press the  key.		00 = initialization disabled, clear trip history only
9	Press the  key.		01 = initialization enabled
10	Press the  key.		Initialization now enabled to restore all defaults
11	Press and hold the  ,  , and  keys. Do not release yet.		First part of special key sequence
12	Holding the keys above, press and hold the  (STOP) key for 3 sec.		Final part of special key sequence
13	Release only the  (STOP) key, and wait for the display  to appear and begin blinking.		Initialization begins when display starts blinking
14	Now release the  ,  , and  keys only after the  display function begins blinking.	 	Default parameter country code shown during initialization process (left-most char displays alternating pattern)
15	Initialization is complete.		Function code for output frequency monitor shown



**NOTE:** Initialization cannot be performed with a remote operator panel. Disconnect the device and use the inverter’s front panel keypad.

## EEPROM Compulsory Initialization

All of EEPROM data are stored default setting

### -method-

1. After setting C091=01, store '\*\*FF' at EEPROM address 11d4(C092 setting).
2. Then press and hold the FUNC, UP, and DOWN key.

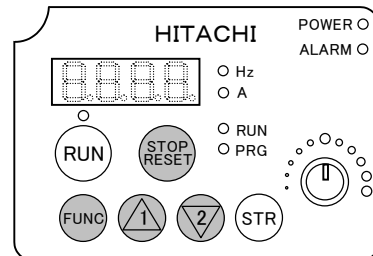

3. After that press RESET key and release.
4. Then INV starts compulsory initialization as it displays like below.

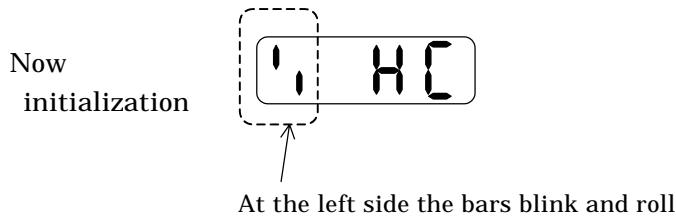

5. EEPROM compulsory initialization completes.
6. Set Voltage-class (C197), and set C195, b085 (both must be the same.)
7. Set INV kW Code (C196) the wrong value once intentionally and store, then set the right value. After that start initialization with b084

### -C081, C082-

O-L adjustment at factory (not C81, not C82)

JPN version is 1 byte definition

Core: up to 3388 (or before)

IO: up to 3433 (or before)

EU/USA version is 2 byte definition from the beginning.

Core: 3440 or after

IO: 3441 or after

When initialization of b084 or copying C081 and C082 are set different value, so need to set again.

ERROR Check

error	description
No display	DC bus charged IO board connection & cable connection OPE connection short bar P1- PD Cooling FAN failure Connection between IO board & OPE(L200)
E08/E11	EEPROM recovery(initialization C92 display 11d4=ff)
E22	IO board connection & cable connection(communication error between ISPM & IO board) INV type code is wrong SJ200 & L200  EEPROM recovery(initialization C92 display 11d4=ff)(because MCU can't read EEPROM)
8888 display	EEPROM data changed. check C194
OC trip/E23/ E30/E14	Disconnect motor wire and check output voltage
---- (Power Off display)	Core(ISPM) failure(not repairable)
E09 with motor	maybe thyristor off, please check waveform of DC bus voltage.
E12(EXT)	check C01-C06 (EXT=12)
E35(PTC)	check C06(SJ200)-C05(L200)(PTC=19) ,check C85 value
E05(Over Load),OC trip(L200)is prematured	check b32 value
Cooling FAN doesn't work	check b92
INV doesn't work	check DIP switch on ISPM(Power Module pcb)
MOV failure, or you got returned INV	check d109 display after C91 set 01
bar-bar-bar-bar display(OPE-S,OPE-SRE, not OPE-Smini) or R-ERROR COMM.<1>(SRW)	Set dip Switch from 485 to PRG
No display	check the bar of P-line.

## Debug Mode

If you set debug mode enable (C091 =01), the function below will be available.  
 When debugging, you can use only standard OPE (cannot use SRW)  
 Make sure of returning C091=00 after debugging.

There are some monitor or function-code for testing and maintenance which is not released for users.

The content of each function follows below.

## Monitor mode

No	Function name	Code	Run Mode Edit	Range	Description	Res.	default	unit
1	Control-frequency monitor	d101	-	0. 0~400. 0	Monitors control frequency	0. 1[Hz]	-	Hz
2	DC voltage monitor	d102	-	0. 0~999. 9	Monitors the P-N voltage	0. 1[V]	-	V
3	BRD ON time monitor	d103	-	0. 0~100. 0	Monitors the time during BRD ON	0. 1[sec]	-	%
4	Electric thermal monitor	d104	-	0. 0~100. 0	Monitors integration of the current when exceeding the thermal level.	0. 1%	-	-
5	Core MCU NO.	d106	-	0000~9999	Monitors the version of the core program	1	-	-
6	IO MCU NO.	d107	-	0000~9999	Monitors the version of the IO program	1	-	-
7	Peak voltage monitor	d109	-	0. 0~999. 9	Monitors the peak P-N voltage	0. 1[V]	-	V

## Function mode

No	Function name	Code	Run Mode Edit	Range	Description	Res.	default	unit
8	Debug mode enable	C091	OK	00(disable)/01(enable)	Debug mode select	-	00	-
9	Debug mode data set	C092	OK	0000~FFFF	Hexadecimal display (Do not set)	-	1200	-
10	Debug mode data monitor	C093	OK	0000~FFFF	Hexadecimal display (Do not set)	-	1200	-
11	Debug mode bit control	C094	OK	Address set range 0000 - FFFF-> 0-7 bit select	Hexadecimal display (Do not set)	-	1200	-
12	Debug mode select	C095	OK	00(Core)/01(IO)	Doesn't store to EEPROM	-	00	-
13	O input span calibration for function test	C121	-	0000~FFFF	Hexadecimal display (Do not set)	-	3E8	-
14	OI input span calibration for function test	C122	-	0000~FFFF	Hexadecimal display (Do not set)	-	3E8	-
15	OI Zero calibration for function test	C123	-	0~65535	(Do not set)	-	200	-
16	Area code select	C195	-	00(JPN)/01(EU)/02(USA)	Area code select	-	-	-
17	kW code	C196	-	0.2~7.5	Capacity select	-	-	-
18	Voltage-class select	C197	-	00(200V)/01(400V)	Voltage-class select	-	-	-

# Maintenance and Inspection

## Monthly and Yearly Inspection Chart

Item Inspected		Check for...	Inspection Cycle		Inspection Method	Criteria
			Month	Year		
Overall	Ambient environment	Extreme temperatures & humidity	✓		Thermometer, hygrometer	Ambient temperature between -10 to 40°C, non-condensing
	Major devices	Abnormal noise & vib.	✓		Visual and aural	Stable environment for electronic controls
	Power supply voltage	Voltage tolerance	✓		Digital volt meter, measure between inverter terminals [L1], [L2], [L3]	200V class: 200 to 240V 50/60 Hz 400V class: 380 to 460V 50/60 Hz
Main circuit	Ground Insulation	Adequate resistance		✓	Digital volt meter, GND to terminals	5 Meg. Ohms or greater
	Mounting	No loose screws		✓	Torque wrench	M3: 0.5 – 0.6 Nm M4: 0.98 – 1.3 Nm M5: 1.5 – 2.0 Nm
	Components	Overheating		✓	Thermal trip events	No trip events
	Housing	Dirt, dust		✓	Visual	Vacuum dust and dirt
	Terminal block	Secure connections		✓	Visual	No abnormalities
	Smoothing capacitor	Leaking, swelling	✓		Visual	No abnormalities
	Relay(s)	Chattering		✓	Aural	Single click when switching ON or OFF
	Resistors	Cracks or discoloring		✓	Visual	Use Ohm meter to check braking resistors
	Cooling fan	Noise	✓		Power down, manually rotate	Rotation must be smooth
	Dust	✓		Visual	Vacuum to clean	
Control circuit	Overall	No odor, discoloring, corrosion		✓	Visual	No abnormalities
	Capacitor	No leaks or deformation	✓		Visual	Undistorted appearance
Display	LEDs	Legibility	✓		Visual	All LED segments work

**Note 1:** The life of a capacitor is affected by the ambient temperature. See “Capacitor Life Curve” on page 6–11.

**Note 2:** The inverter must be cleaned periodically. If dust accumulates on the fan and heat sink, it can cause overheating of the inverter.

## Megger Test

The *megger* is a piece of test equipment that uses a high voltage to determine if an insulation degradation has occurred. For inverters, it is important that the power terminals be isolated from the Earth GND terminal via the proper amount of insulation.

The circuit diagram below shows the inverter wiring for performing the megger test. Just follow the steps to perform the test:

1. Remove power from the inverter and wait at least 5 minutes before proceeding.
2. Open the front housing panel to access the power wiring.
3. Remove all wires to terminals [R, S, T, RB, PD/+1, PD/+, N/-, U, V, and W]. Most importantly, the input power and motor wires will be disconnected from the inverter.
4. Use a bare wire and short terminals [R, S, T, RB, PD/+1, PD/+, N/-, U, V, and W] together as shown in the diagram.
5. Connect the megger to the inverter Earth GND and to the shorted power terminals as shown. Then perform the megger test at 500 VDC and verify 5M $\Omega$  or greater resistance.

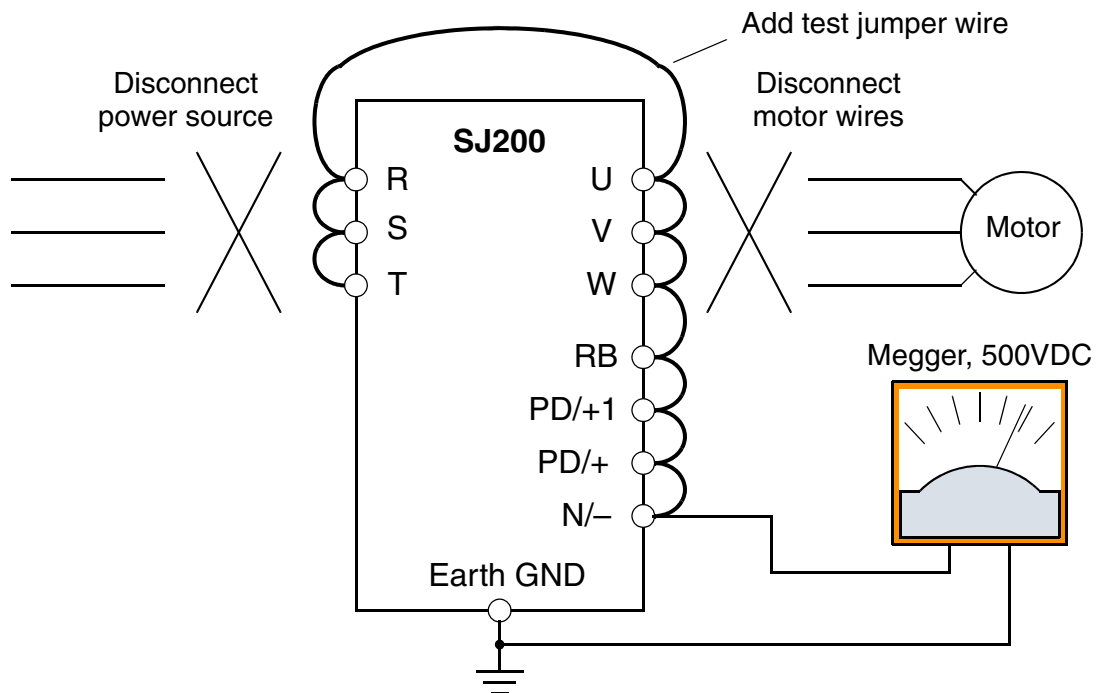

6. After completing the test, disconnect the megger from the inverter.
7. Reconnect the original wires to terminals [R, S, T, RB, PD/+1, PD/+, N/-, U, V, and W].



**CAUTION:** Do not connect the megger to any control circuit terminals such as intelligent I/O, analog terminals, etc. Doing so could cause damage to the inverter.



**CAUTION:** Never test the withstand voltage (HIPOT) on the inverter. The inverter has a surge protector between the main circuit terminals above and the chassis ground.

### Spare parts

We recommend that you stock spare parts to reduce down time, including these parts:

Part description	Symbol	Quantity		Notes
		Used	Spare	
Cooling fan	FAN	1	1	015NF, 022NF, 030LF, 015HF to 075HF
Case	CV	1	1	<ul style="list-style-type: none"> <li>• Front case</li> <li>• Key cover</li> <li>• Case</li> <li>• Bottom cover</li> </ul>

### Capacitor Life Curve

The DC bus inside the inverter uses a large capacitor as shown in the diagram below. The capacitor handles high voltage and current as it smooths the power for use by the inverter. So, any degradation of the capacitor will affect the performance of the inverter.

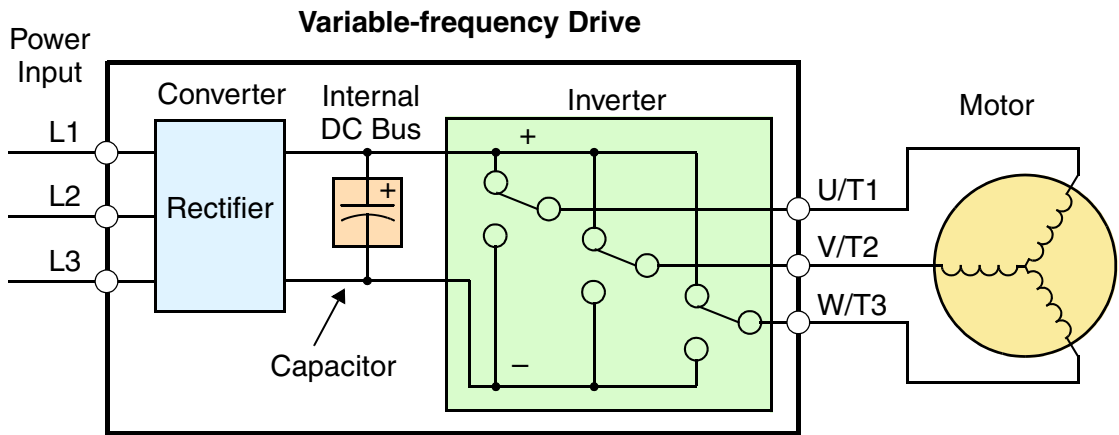

Capacitor life is reduced in higher ambient temperatures, as the graph below demonstrates. Be sure to keep the ambient temperature at acceptable levels, and perform maintenance inspections on the fan, heat sink, and other components. If the inverter is installed on a cabinet, the ambient temperature is the temperature inside the cabinet.

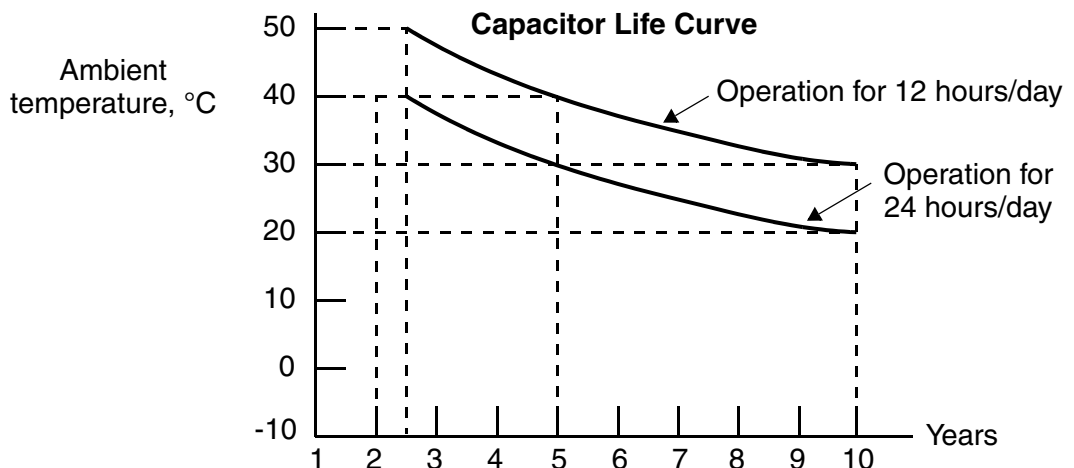

## General Inverter Electrical Measurements

The following table specifies how to measure key system electrical parameters. The diagrams on the next page show inverter-motor systems and the location of measurement points for these parameters.

Parameter	Circuit location of measurement	Measuring instrument	Notes	Reference Value
Supply voltage $E_1$	$E_R$ – across L1 and L2 $E_S$ – across L2 and L3 $E_T$ – across L3 and L1	Moving-coil type voltmeter or rectifier type voltmeter	Fundamental wave effective value	Commercial supply voltage (200V class) 200–240V, 50/60 Hz 400V class 380–460V, 50/60 Hz
Supply current $I_1$	$I_R$ – L1, $I_S$ – L2, $I_T$ – L3		Total effective value	—
Supply power $W_1$	$W_{11}$ – across L1 and L2 $W_{12}$ – across L2 and L3		Total effective value	—
Supply power factor $Pf_1$	$Pf_1 = \frac{W_1}{\sqrt{3} \times E_1 \times I_1} \times 100\%$			—
Output voltage $E_0$	$E_U$ – across U and V $E_V$ – across V and W $E_W$ – across W and U	Rectifier type voltmeter	Total effective value	—
Output current $I_0$	$I_U$ – U $I_V$ – V $I_W$ – W	Moving-coil ammeter	Total effective value	—
Output power $W_0$	$W_{01}$ – across U and V $W_{02}$ – across V and W	Electronic type wattmeter	Total effective value	—
Output power factor $Pf_0$	Calculate the output power factor from the output voltage E, output current I, and output power W. $Pf_0 = \frac{W_0}{\sqrt{3} \times E_0 \times I_0} \times 100\%$			—

- Note 1:** Use a meter indicating a fundamental wave effective value for voltage, and meters indicating total effective values for current and power.
- Note 2:** The inverter output has a distorted waveform, and low frequencies may cause erroneous readings. However, the measuring instruments and methods listed above provide comparably accurate results.
- Note 3:** A general-purpose digital volt meter (DVM) is not usually suitable to measure a distorted waveform (not pure sinusoid).



The figures below show measurement locations for voltage, current, and power measurements listed in the table on the previous page. The voltage to be measured is the fundamental wave effective voltage. The power to be measured is the total effective power.

**Single-phase Measurement Diagram**

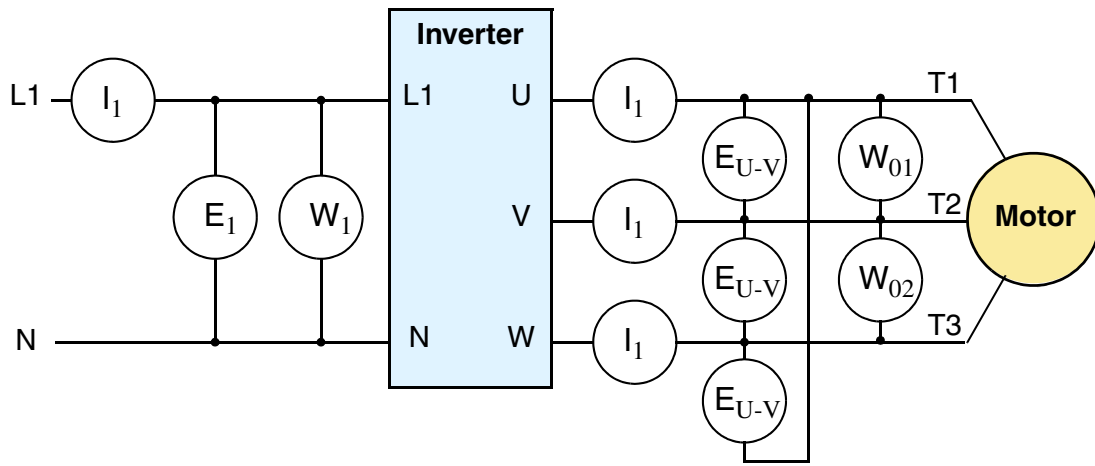

**Three-phase Measurement Diagram**

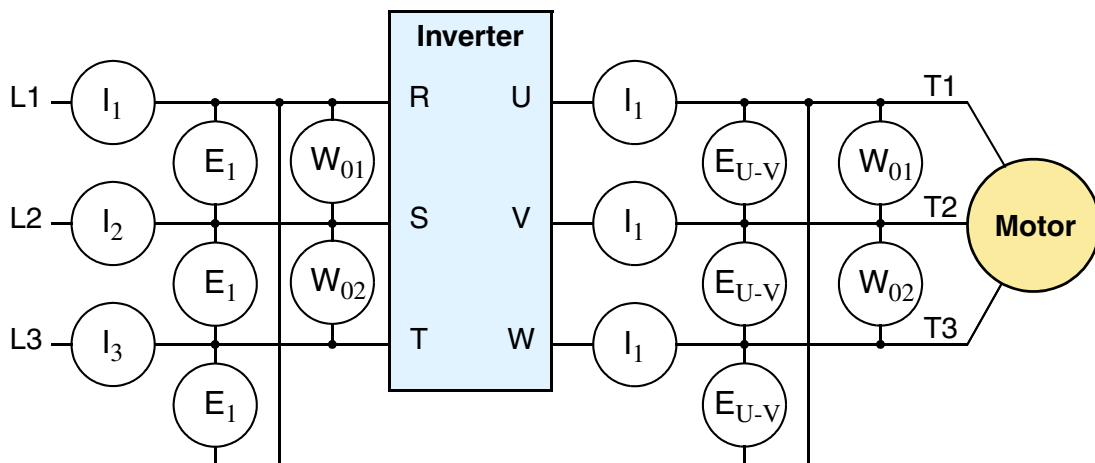

## Inverter Output Voltage Measurement Techniques

Taking voltage measurements around drives equipment requires the right equipment and a safe approach. You are working with high voltages and high-frequency switching waveforms that are not pure sinusoids. Digital voltmeters will not usually produce reliable readings for these waveforms. And, it is usually risky to connect high voltage signals to oscilloscopes. The inverter output semiconductors have some leakage, and no-load measurements produce misleading results. So, we highly recommend using the following circuits to measure voltage for performing the equipment inspections.

**Voltage measurement *with load***

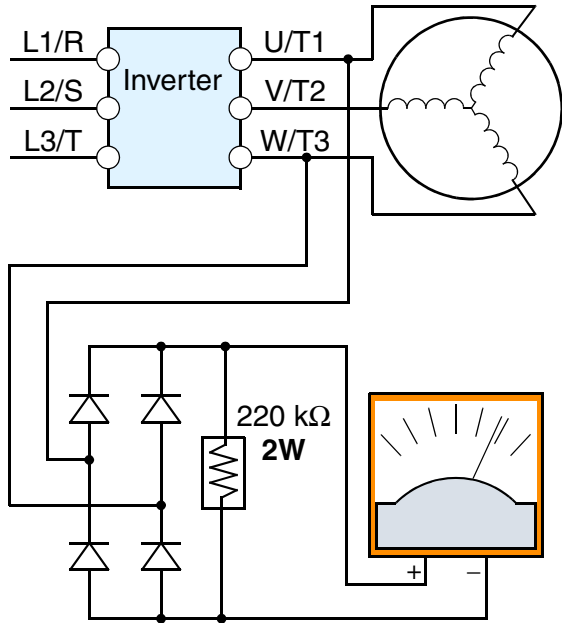

V Class	Diode Bridge	Voltmeter
200V Class	600V 0.01A min.	300V range
400V Class	100V 0.1A min.	600V range

**Voltage measurement *without load***

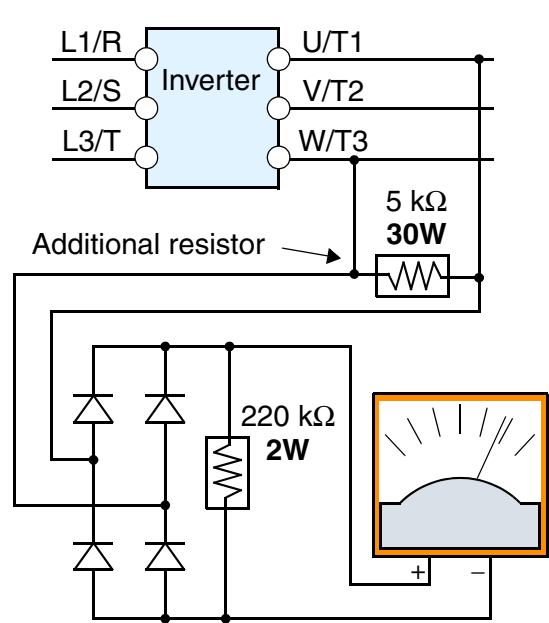

V Class	Diode Bridge	Voltmeter
200V Class	600V 0.01A min.	300V range
400V Class	100V 0.1A min.	600V range



**HIGH VOLTAGE:** Be careful not to touch wiring or connector terminals when working with the inverters and taking measurements. Be sure to place the measurement circuitry components above in an insulated housing before using them.

### IGBT Test Method

The following procedure will check the inverter transistors (IGBTs) and diodes:

1. Disconnect input power to terminals [R, S, and T] and motor terminals [U, V, and W].
2. Disconnect any wires from terminals [+] and [RB] for regenerative braking.
3. Use a Digital Volt Meter (DVM) and set it for 1Ω resistance range. You can check the status of the charging state of terminals [R, S, T, U, V, W, RB, +, and -] of the inverter and the probe of the DVM by measuring the charging state.

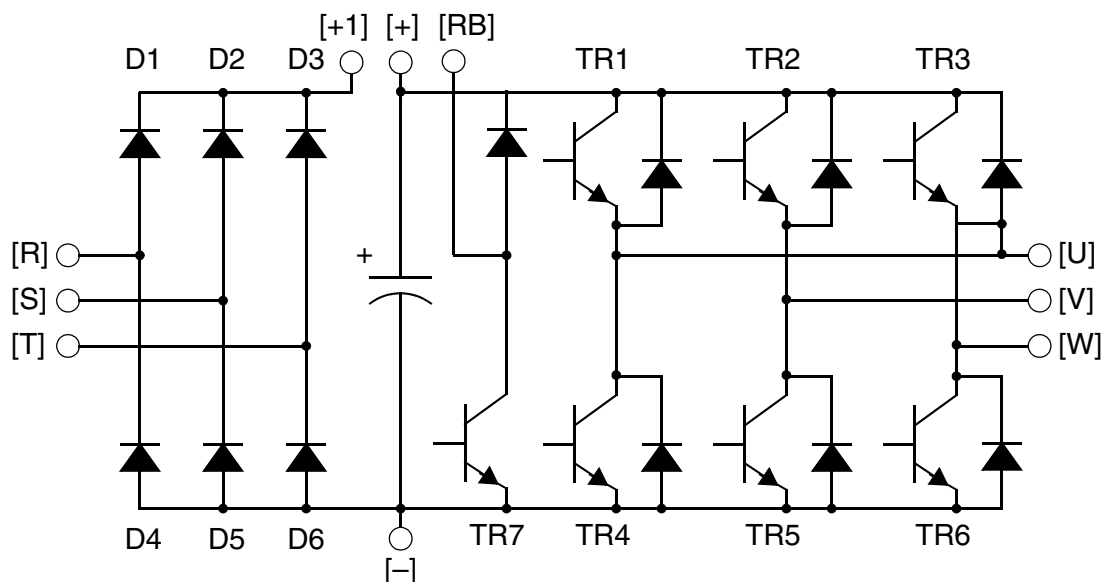

**Table Legend** – Almost infinite resistance:  $\cong \infty \Omega$  Almost zero resistance:  $\cong 0 \Omega$

Part	DVM		Measured Value	Part	DVM		Measured Value	Part	DVM		Measured Value
	+	-			+	-			+	-	
D1	[R]	+1	$\cong \infty \Omega$	D5	[S]	[N]	$\cong 0 \Omega$	TR4	[U]	[-]	$\cong 0 \Omega$
	+1	[R]	$\cong 0 \Omega$		[N]	[S]	$\cong \infty \Omega$		[-]	[U]	$\cong \infty \Omega$
D2	[S]	+1	$\cong \infty \Omega$	D6	[T]	[N]	$\cong 0 \Omega$	TR5	[V]	[-]	$\cong 0 \Omega$
	+1	[S]	$\cong 0 \Omega$		[N]	[T]	$\cong \infty \Omega$		[-]	[V]	$\cong \infty \Omega$
D3	[T]	+1	$\cong \infty \Omega$	TR1	[U]	[+]	$\cong \infty \Omega$	TR6	[W]	[-]	$\cong 0 \Omega$
	+1	[T]	$\cong 0 \Omega$		[+]	[U]	$\cong 0 \Omega$		[-]	[W]	$\cong \infty \Omega$
D4	[R]	[N]	$\cong 0 \Omega$	TR2	[V]	[+]	$\cong \infty \Omega$	TR7	[RB]	[+]	$\cong 0 \Omega$
	[N]	[R]	$\cong \infty \Omega$		[+]	[V]	$\cong 0 \Omega$		[+]	[RB]	$\cong \infty \Omega$
				TR3	[W]	[+]	$\cong \infty \Omega$	[RB]	[-]	$\cong 0 \Omega$	
					[+]	[W]	$\cong 0 \Omega$	[-]	[RB]	$\cong 0 \Omega$	



**NOTE:** The resistance values for the diodes or the transistors will not be exactly the same, but they will be close. If you find a significance difference, a problem may exist.



**NOTE:** Before measuring the voltage between [+] and [-] with the DC current range, confirm that the smoothing capacitor is discharged fully, then execute the tests.

## Replacing the fan

The following series inverter is equipped a cooling fan.

(200V class): 1,5kW, 2.2kW, 3.7kW

(400V class): 1,5kW, 2.2kW, 3.7kW

A way to replace the fan follows below.

By the way, primary released product is different from not primary (secondly -) one about the way to remove the fan. In the case of replacing the fan, please remove the housing cover first, and then replace the new fan. Please refer to section 4.6 about the way to remove the housing cover.

Please make sure of the specification label to discriminate whether it's primary released product or not.

REV.NO.: A - primary released products

REV.NO.: not A - not primary (secondly -) released products

- 1.Insert the minus screw driver etc to the insert point, and remove the upper cover.
- 2.Remove the connector (CN4) of the fan.
- 3.Remove the fan cover and replace new one.

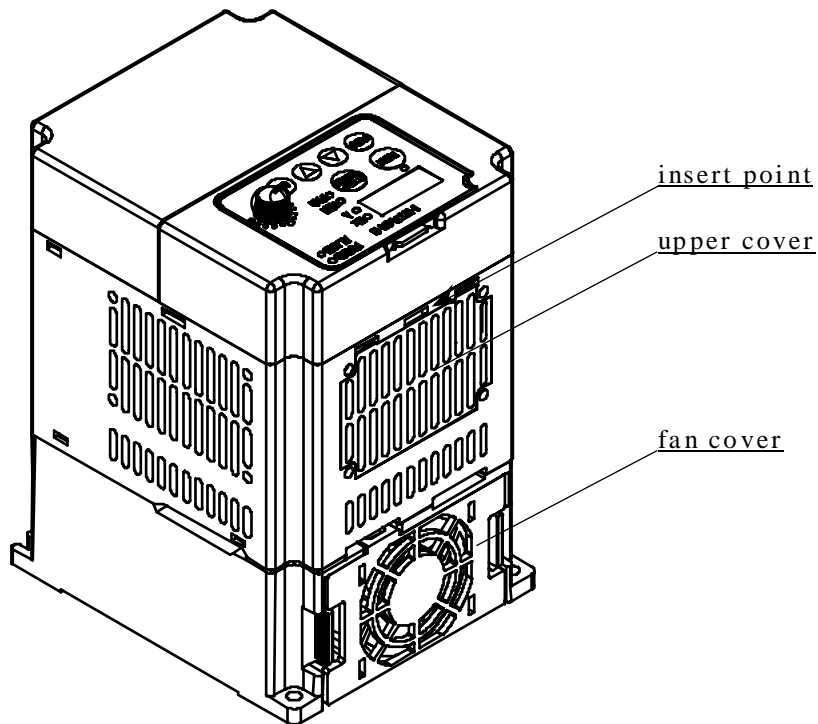

## Removing the housing cover

There are several ways which depend on the scale of the housing cover.

scale (small) : (200V class ) 0.2kW, 0.4kW, 0.75kW

scale (middle): (200V class ) 1.5kW, 2.2kW, 3.7kW

(400V class ) 0.4kW – 3.7kW

### Scale (small)

1. Remove the monitor cover, front cover and rear cover.

When removing the monitor cover, please remove the communication cable from the front cover side.

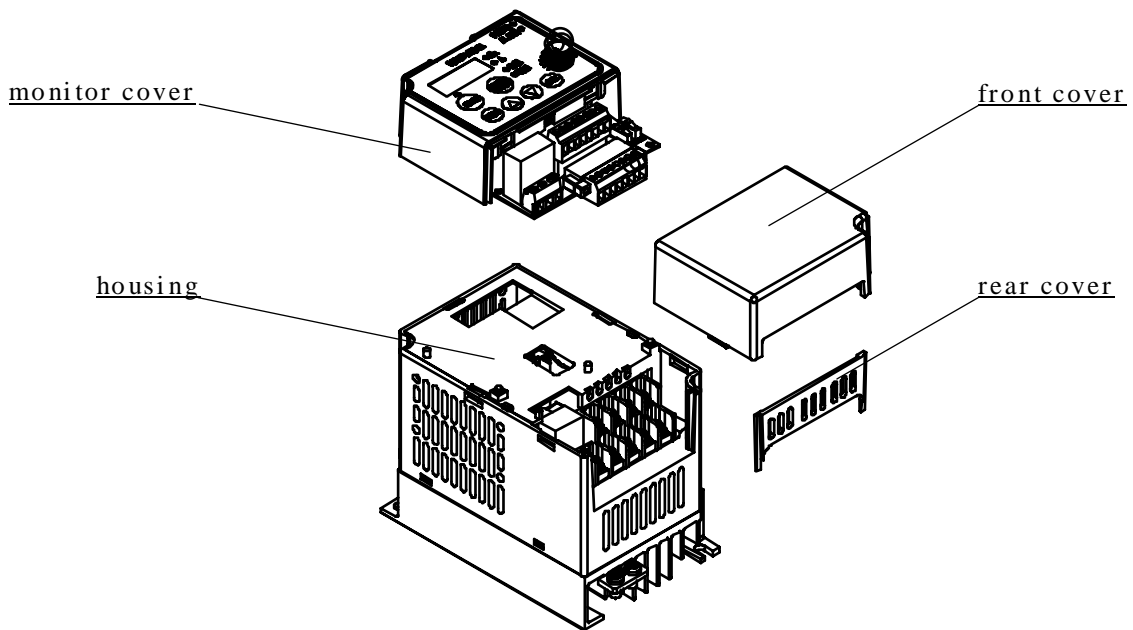

2. Insert the minus screw driver between the cooling fin and the housing, and unlock the tabs (4 points at the left and right side) .

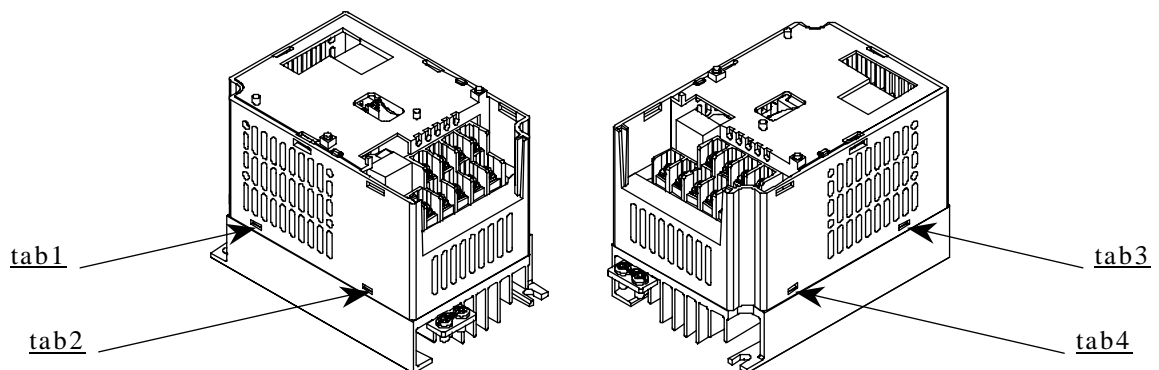

3. Remove the housing.

## Scale (middle)

1.Remove the monitor cover, front cover and rear cover.

When removing the monitor cover, please remove the communication cable from the front cover side.

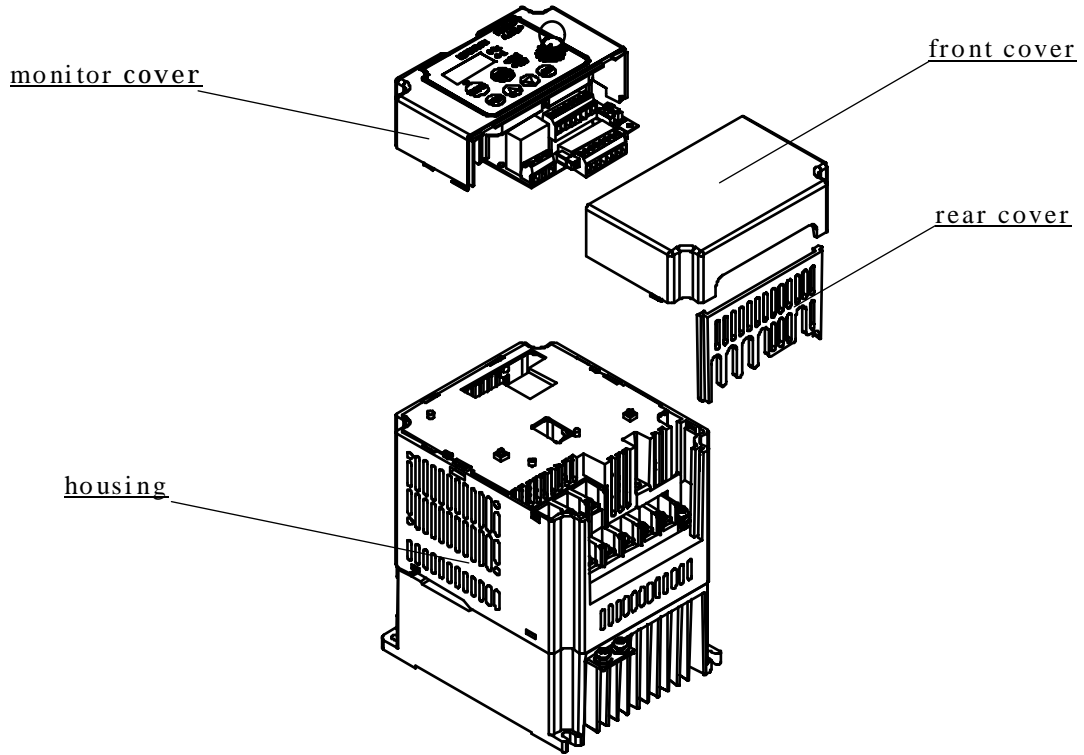

2.Remove the RB-bar.

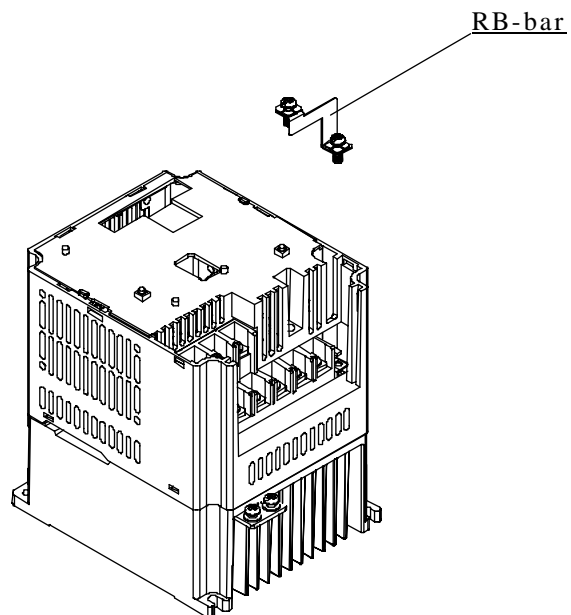

3. Insert the minus screw driver between the cooling fin and the housing, and unlock the tabs (4 points at the left and right side).

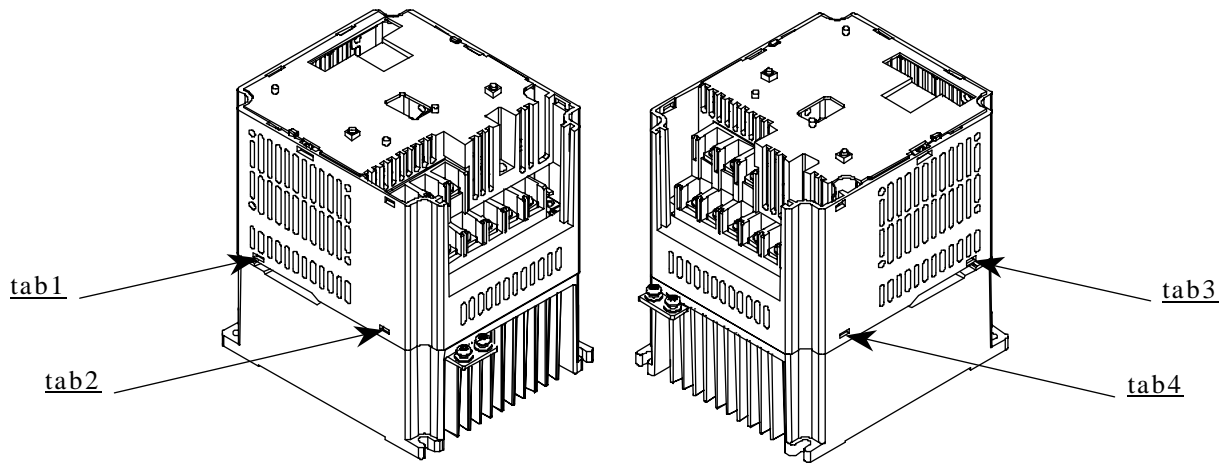

4. Remove the housing.

## Scale (large)

- ① Remove the monitor cover, front cover and rear cover.

When removing the monitor cover, please remove the communication cable from the front cover side.

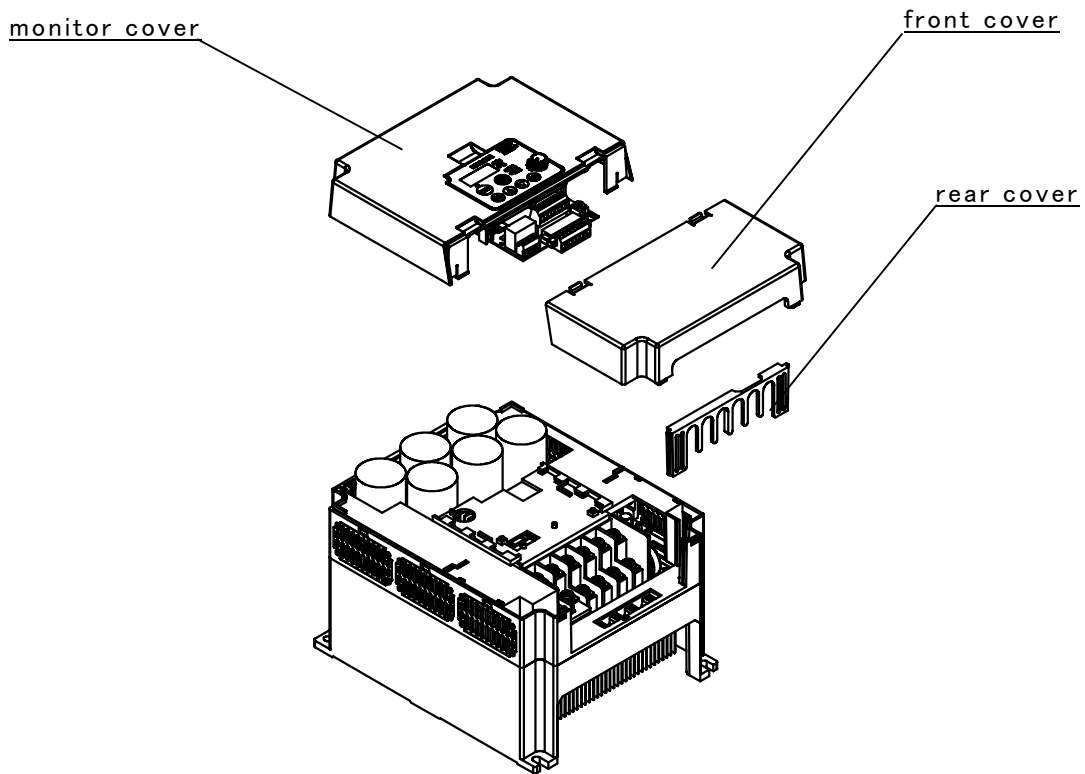

- ② Remove the two bolts and P-PD short bar.

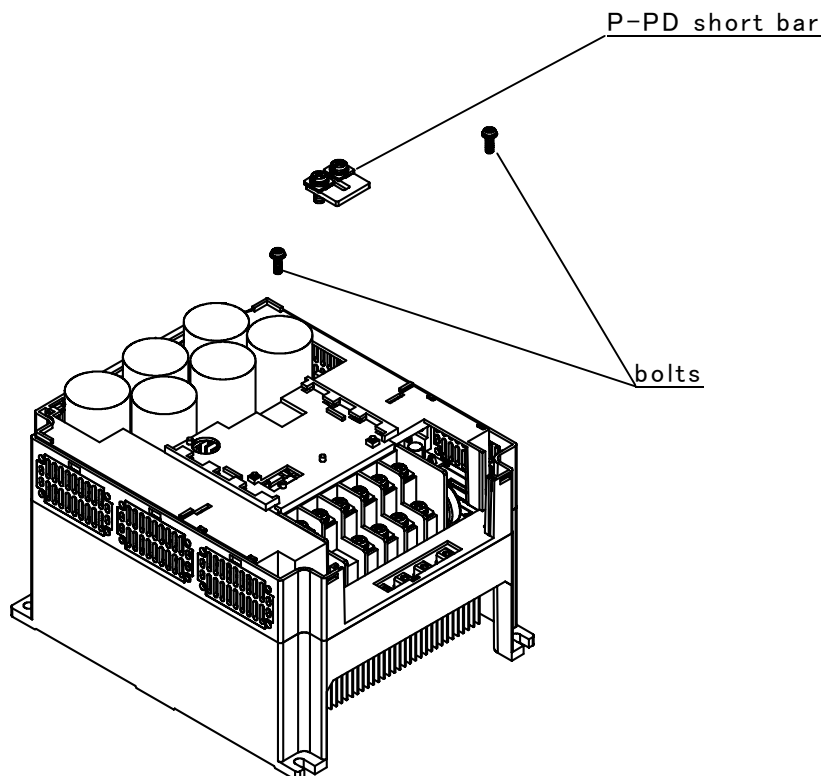



③ Remove the housing

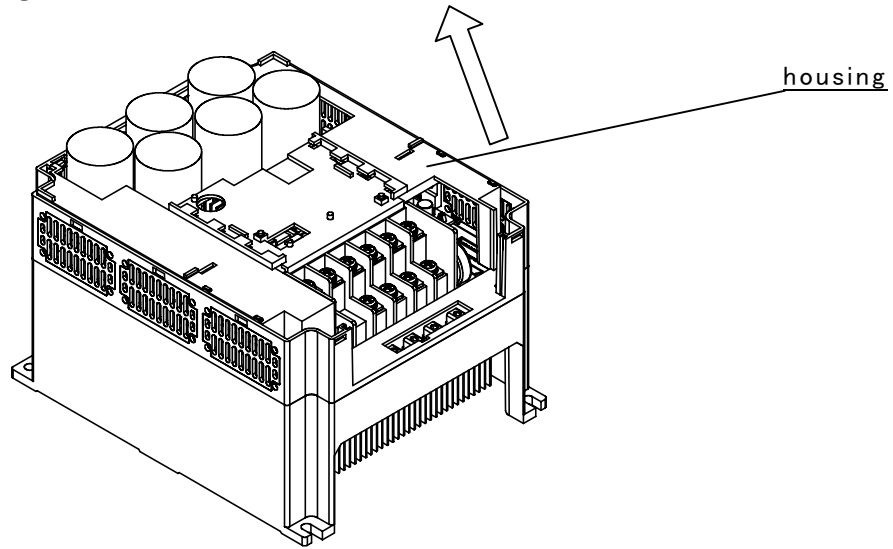

A B C D E

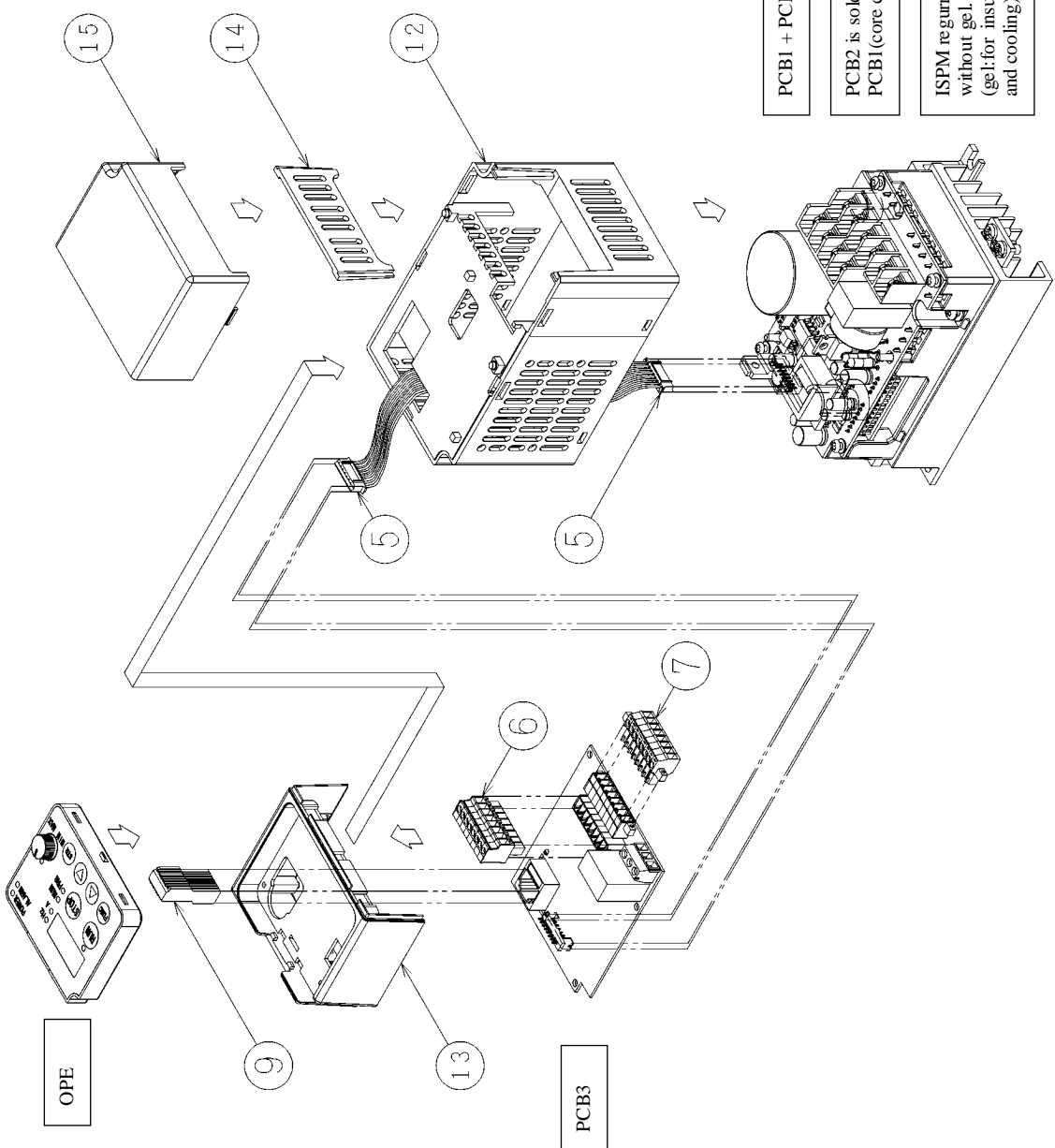

品番	部品略称	部品名	1台分 使用数量
5	WIRE	通信ケーブル	1
6	PLG	制御回路端子台 (TM1C)	1
7	PLG	制御回路端子台B (TM2C)	1
9	PLG	デジタルオプレーター中継プラグ	1
12	CS	ケース	1
13	CV	表面カバー	1
14	CV	リアカバー	1
15	CV	フロントカバー	1

御社主	CUSTOMER	数量 QTY.	受注番号 ORDER No.	作業番号 WORK No.	REV.
日立製作所	日立製作所				
DNW	CHKO	APR-03-2004	APR-07-2004	APR-07-2004	
Hitachi Industrial Equipment Systems Co., Ltd.			NARASHINO WORKS DWG No.	SH.	
			3243T829643		
				構造 ☑	
				枠 号 FRAME SIZE	

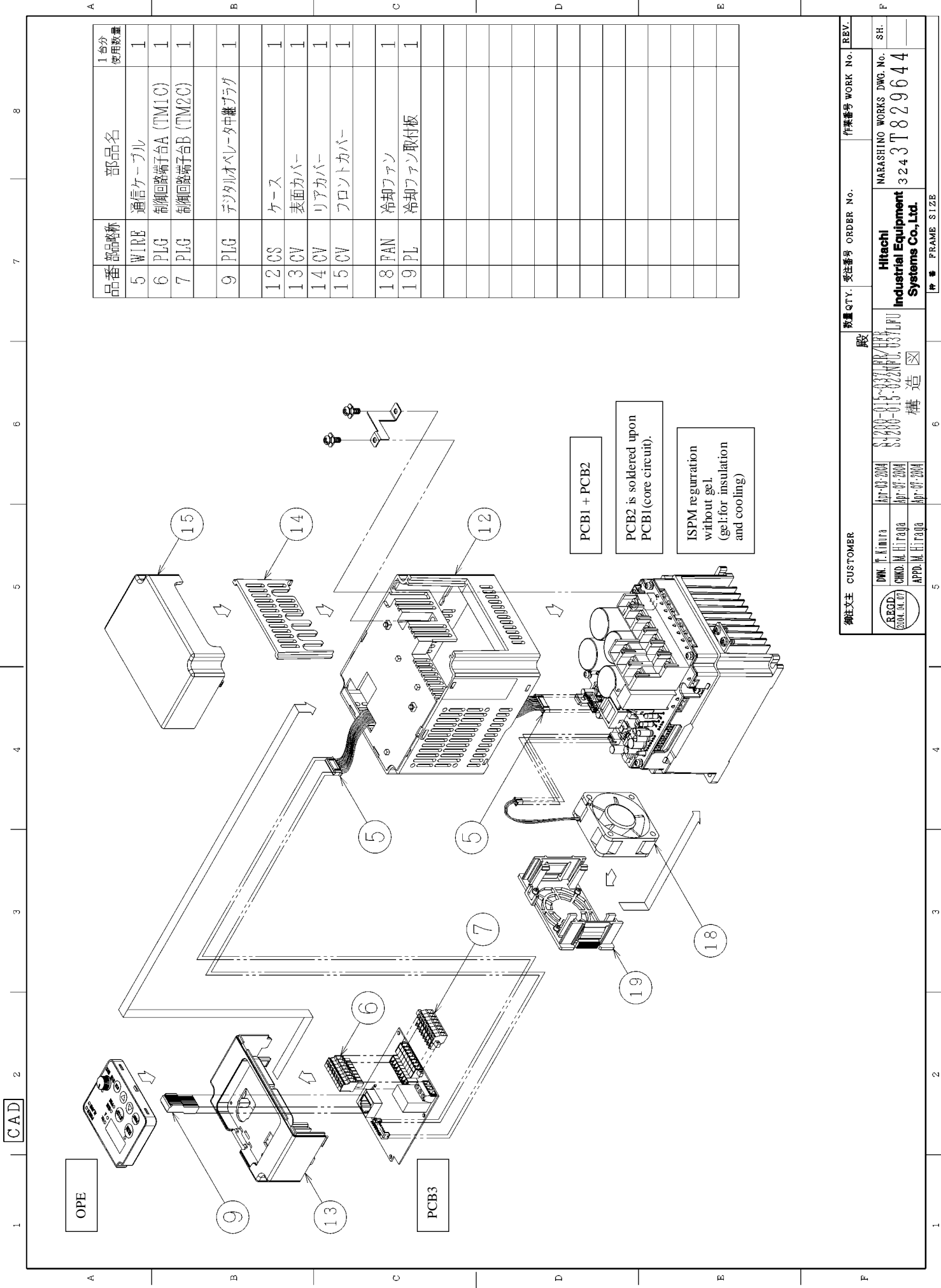

品番	部品名称	部品名	1台分 使用数量
5	WIRE	通信ケーブル	1
6	PLG	制御回路端子台A (TM1C)	1
7	PLG	制御回路端子台B (TM2C)	1
9	PLG	デジタルオペレータ中継プラグ	1
12	CS	ケース	1
13	CV	表面カバー	1
14	CV	リアカバー	1
15	CV	フロントカバー	1
18	FAN	冷却ファン	1
19	PL	冷却ファン取付板	1

CAD

御注文主 CUSTOMER: 株式会社 日立製作所  
 数量 QTY.: 1  
 受注番号 ORDER No.: 3243T829644  
 作業番号 WORK No.:  
 構造 ☑  
 種 号 FRAME SIZE:

REC'D 2004.04.07	CHK'D Hitachi	APP'D Hitachi	DATE Apr-07-2004	DATE Apr-07-2004	DATE Apr-07-2004
DWG. T. Kimura			S.2000-013-0037 (REV.00)		
CHKD. M. Hirano			S.2000-013-0224 (REV.00)		
APPD. M. Hirano			S.2000-013-0224 (REV.00)		

Hitachi Industrial Equipment Systems Co., Ltd.  
 NARASHINO WORKS DWG. No. 3243T829644 SH.

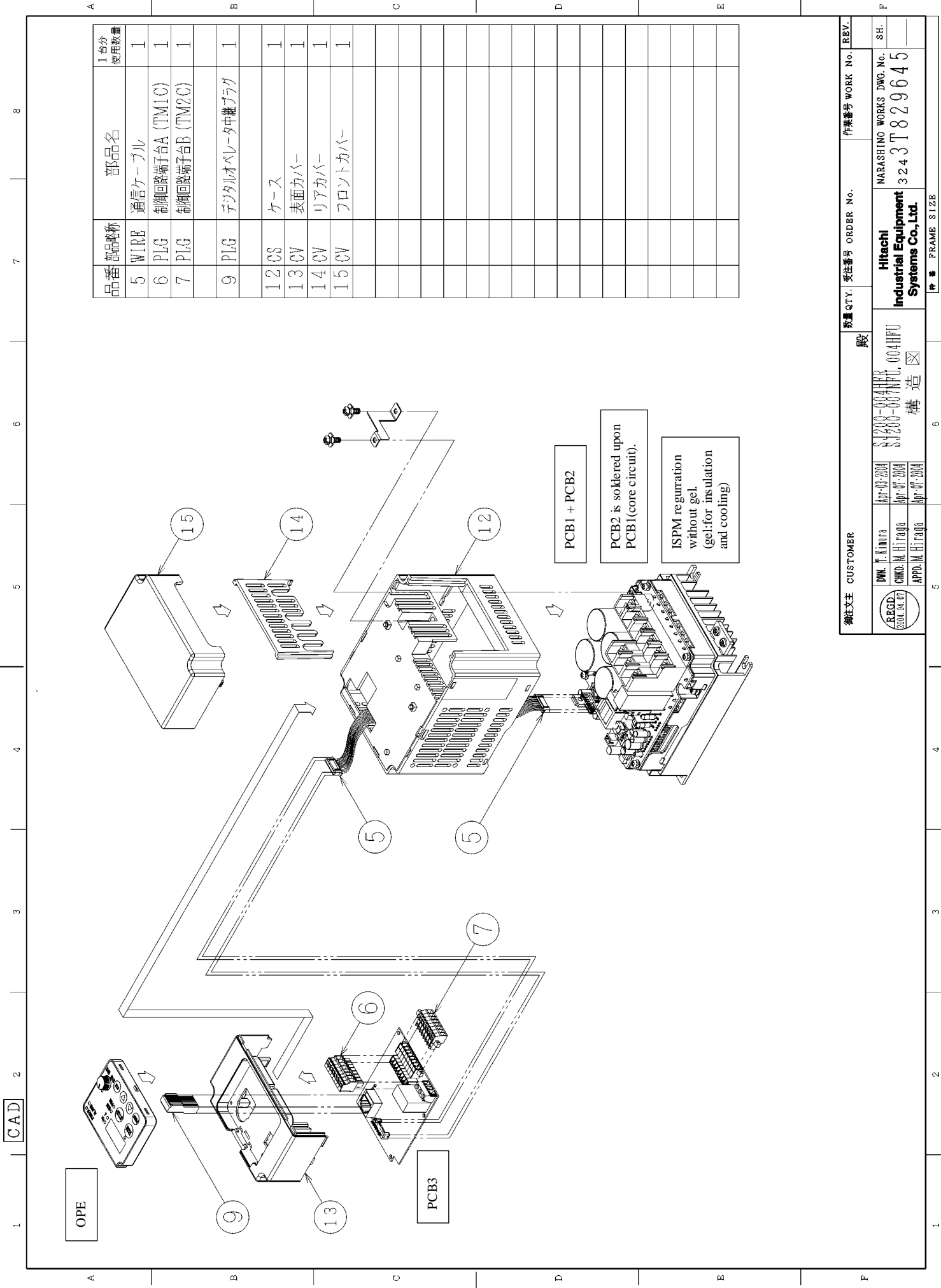

品番	部品名称	部品名	1台分 使用数量
5	WIRE	通信ケーブル	1
6	PLG	制御回路端子台A (TM1C)	1
7	PLG	制御回路端子台B (TM2C)	1
9	PLG	デジタルオペレータ中継プラグ	1
12	CS	ケース	1
13	CV	表面カバー	1
14	CV	リアカバー	1
15	CV	フロントカバー	1

御注文主 CUSTOMER		数量 QTY.	受注番号 ORDER No.	作業番号 WORK No.	REV.
Hitachi Industrial Equipment Systems Co., Ltd.					
MARASHINO WORKS DWG. No.		3243T829645			
SH.					
DWN. H. Kimura		SUSU-034HPP			
CHKD. M. Hiraoka		SUZU-037NFC, 004HFU			
APPD. M. Hiraoka		構造 ☒			
RECD. 2004.04.07					
DATE: 03.2004					
DATE: 03.2004					
DATE: 03.2004					
DATE: 03.2004					
		種 号 FRAME SIZE			

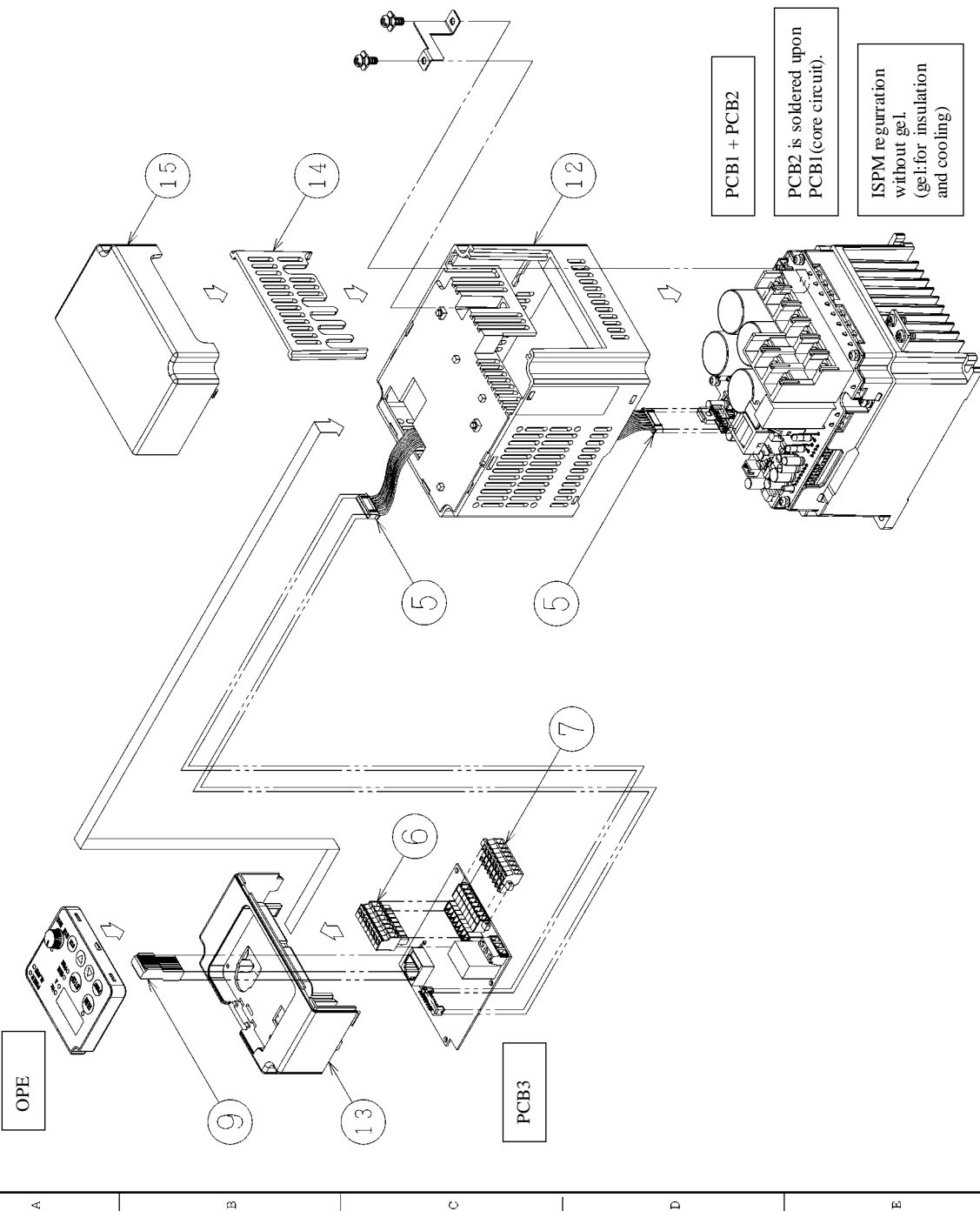

品番	部品名	1台分 使用数量
5	通信ケーブル	1
6	制御回路端子台 (TM1C)	1
7	制御回路端子台 (TM2C)	1
9	デジタルオペレーター中継ブラグ	1
12 CS	ケース	1
13 CV	表面カバー	1
14 CV	リアカバー	1
15 CV	フロントカバー	1

Hitachi  
Industrial Equipment  
Systems Co., Ltd.

顧客文書 CUSTOMER		数量 QTY.	受注番号 ORDER No.	作業番号 WORK No.	REV.
株式会社 日立 製作所					
DNW. 田 嶋 洋 平	APR-07-2004	SU288-887HF0		NARASHINO WORKS DWG. No.	SH.
CHKD. 田 嶋 洋 平	APR-07-2004			3243T829646	
APPD. 田 嶋 洋 平	APR-07-2004			構造 ☑	
RECD. 2004.04.07				種 番 FRAME SIZE	

5.1.構造図(5/11)

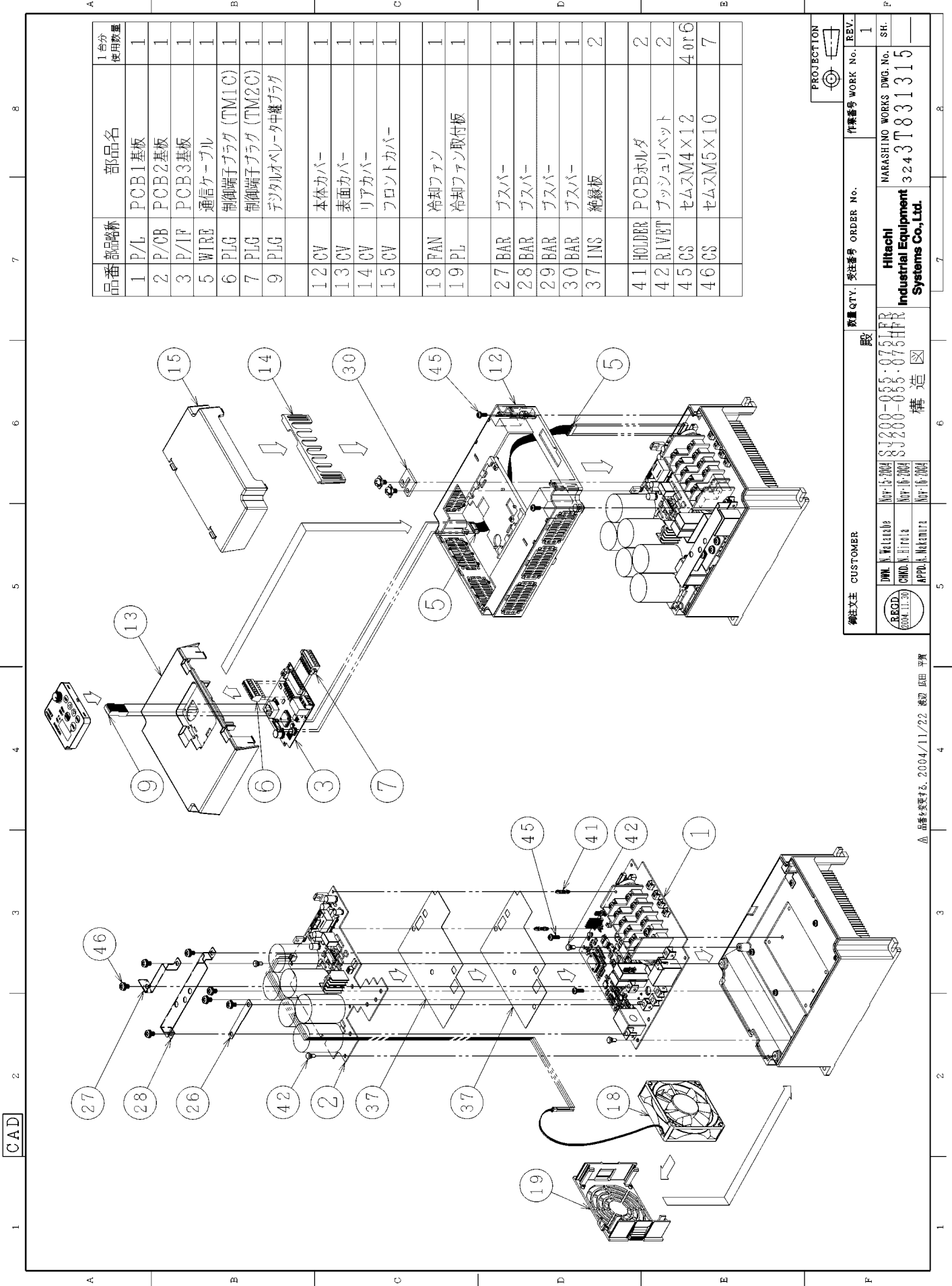

品番	部品略称	部品名	1台分 使用数量
1	P/L	PCB1基板	1
2	P/0B	PCB2基板	1
3	P/1F	PCB3基板	1
5	WIRE	通信ケーブル	1
6	PLG	制御端子プラグ (TM1C)	1
7	PLG	制御端子プラグ (TM2C)	1
9	PLG	デジタルオプレータ中継プラグ	1
12	CV	本体カバー	1
13	CV	表面カバー	1
14	CV	リアカバー	1
15	CV	フロントカバー	1
18	FAN	冷却ファン	1
19	PL	冷却ファン取付板	1
27	BAR	バスバー	1
28	BAR	バスバー	1
29	BAR	バスバー	1
30	BAR	バスバー	1
37	INS	絶縁板	2
41	HOLDER	PCBホルダ	2
42	RIVET	フッシュリベット	2
45	CS	セムSM4×12	4or6
46	CS	セムSM5×10	7

PROJECTION

数量 QTY.	受注番号 ORDER No.	作業番号 WORK No.	REV.
1		1	1

編注文主 CUSTOMER

REGD. 2004.11.30	APPD. A. Nakamura	NOV-16-2004	構造
CHKD. M. Hirota	NOV-16-2004	83200-055-0754RR	Hitachi
APPD. N. Wakabayashi	NOV-16-2004	83200-055-0754RR	NARASHINO WORKS
			DWG. No.
			3243T831315
			SH.

CAD

5.1.構造図(6/11)

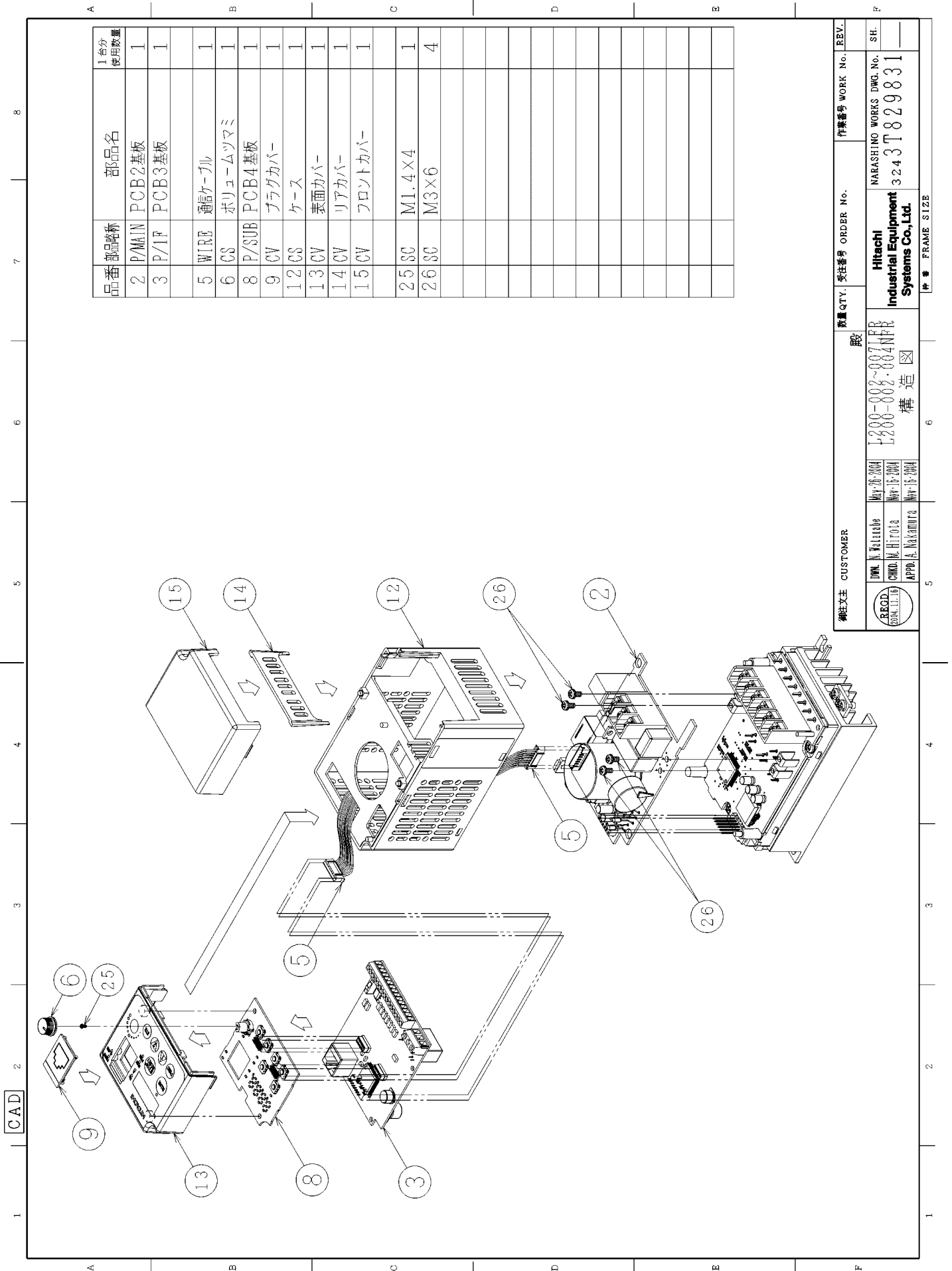

品番	部品略称	部品名	1台分 使用数量
2	P/MAIN	PCB2基板	1
3	P/IF	PCB3基板	1
5	WIRE	通信ケーブル	1
6	CS	ポリウレタムツマミ	1
8	P/SUB	PCB4基板	1
9	CV	プラグカバ-	1
12	CS	ケース	1
13	CV	表面カバ-	1
14	CV	リアカバ-	1
15	CV	フロントカバ-	1
25	SC	M1.4×4	1
26	SC	M3×6	4

御注文主	CUSTOMER	数量	QTY.	受注番号	ORDER No.	作業番号	WORK No.	REV.
		1200-002~007 1200-002-004NFR		1200-002~007 1200-002-004NFR		3243T829831		SH.
株式会社日立製作所 日立工業システムズ株式会社		株式会社日立製作所 日立工業システムズ株式会社		株式会社日立製作所 日立工業システムズ株式会社		株式会社日立製作所 日立工業システムズ株式会社		—
日立製作所 日立工業システムズ株式会社		日立製作所 日立工業システムズ株式会社		日立製作所 日立工業システムズ株式会社		日立製作所 日立工業システムズ株式会社		—

CAD

5.1.構造図(7/11)

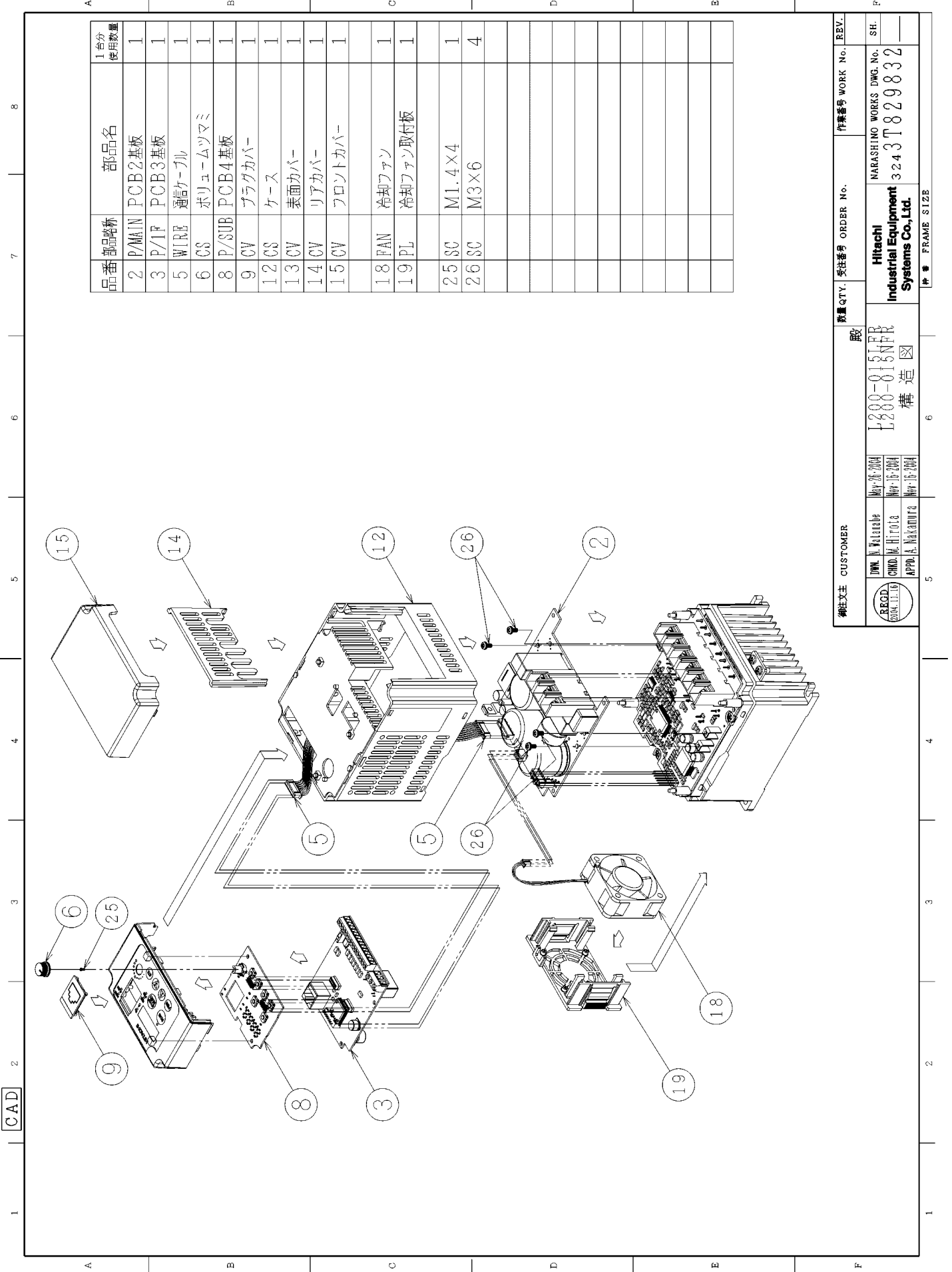

品番	部品略称	部品名	1 台分 使用数量
2	P/MAIN	PCB2基板	1
3	P/IF	PCB3基板	1
5	WIRE	通信ケーブル	1
6	CS	ポリウレタンツマミ	1
8	P/SUB	PCB4基板	1
9	CV	プラグカバー	1
12	CS	ケース	1
13	CV	表面カバー	1
14	CV	リアカバー	1
15	CV	フロントカバー	1
18	FAN	冷却ファン	1
19	PL	冷却ファン取付板	1
25	SC	M1.4×4	1
26	SC	M3×6	4

御注文主	CUSTOMER	数量	QTY.	受注番号	ORDER No.	作業番号	WORK No.	REV.
		股 構造		3243T829832		作業番号 WORK No.		REV.
株式会社日立システムズ 日立システムズ株式会社		株式会社日立システムズ 日立システムズ株式会社		日立システムズ株式会社 日立システムズ株式会社		日立システムズ株式会社 日立システムズ株式会社		REV.
日立システムズ株式会社 日立システムズ株式会社		日立システムズ株式会社 日立システムズ株式会社		日立システムズ株式会社 日立システムズ株式会社		日立システムズ株式会社 日立システムズ株式会社		REV.

CAD



5.1.構造図(8/11)

CAD

1 2 3 4 5 6 7 8

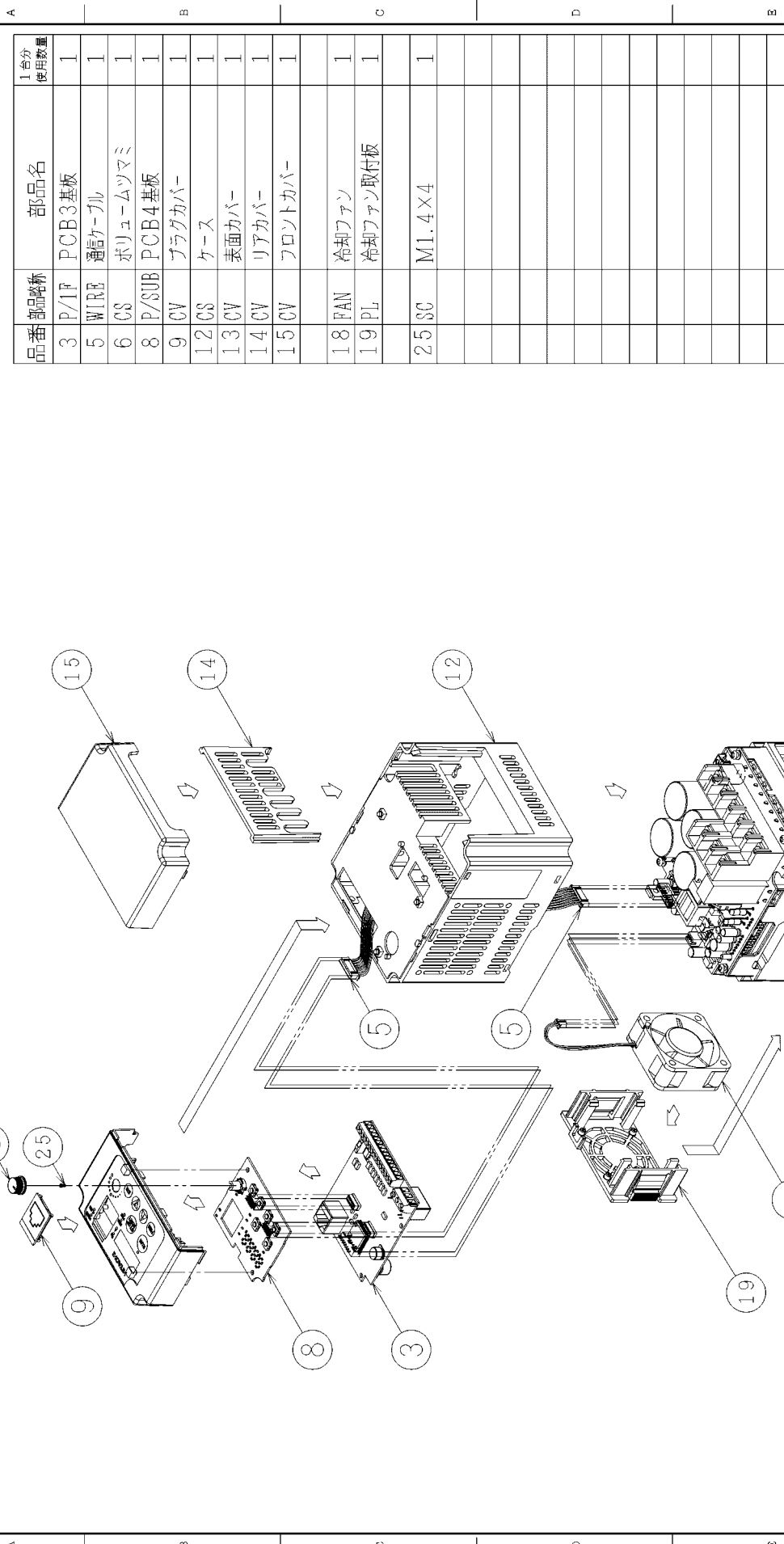

品番	部品略称	部品名	1 台分 使用数量
3	P/IP	PCB3基板	1
5	WIRE	通信ケーブル	1
6	CS	ポリウムツマミ	1
8	P/SUB	PCB4基板	1
9	CV	プラグカバー	1
12	CS	ケース	1
13	CV	表面カバー	1
14	CV	リアカバー	1
15	CV	フロントカバー	1
18	FAN	冷却ファン	1
19	PL	冷却ファン取付板	1
25	SC	M1.4×4	1

御注文 顧客	数量 QTY.	受注番号 ORDER No.	作業番号 WORK No.	REV.
東芝システム工業株式会社	1			
REGD. (INC. IN J.)	DATE: 2004.02.24	200-022-0371	0221P	
DMN. N. Wakabayashi	DATE: 2004.02.24	200-022-0371	0221P	
CHD. M. Hironaka	DATE: 2004.02.24	200-016-0401	構造	
APPD. A. Makamura	DATE: 2004.02.24			
Hitachi Industrial Equipment Systems Co., Ltd.		NARASHINO WORKS		DWG. No.
		3243T829833		SH.
		枠 号 FRAME SIZE		

5.1.構造図(9/11)

CAD 1 2 3 4 5 6 7 8

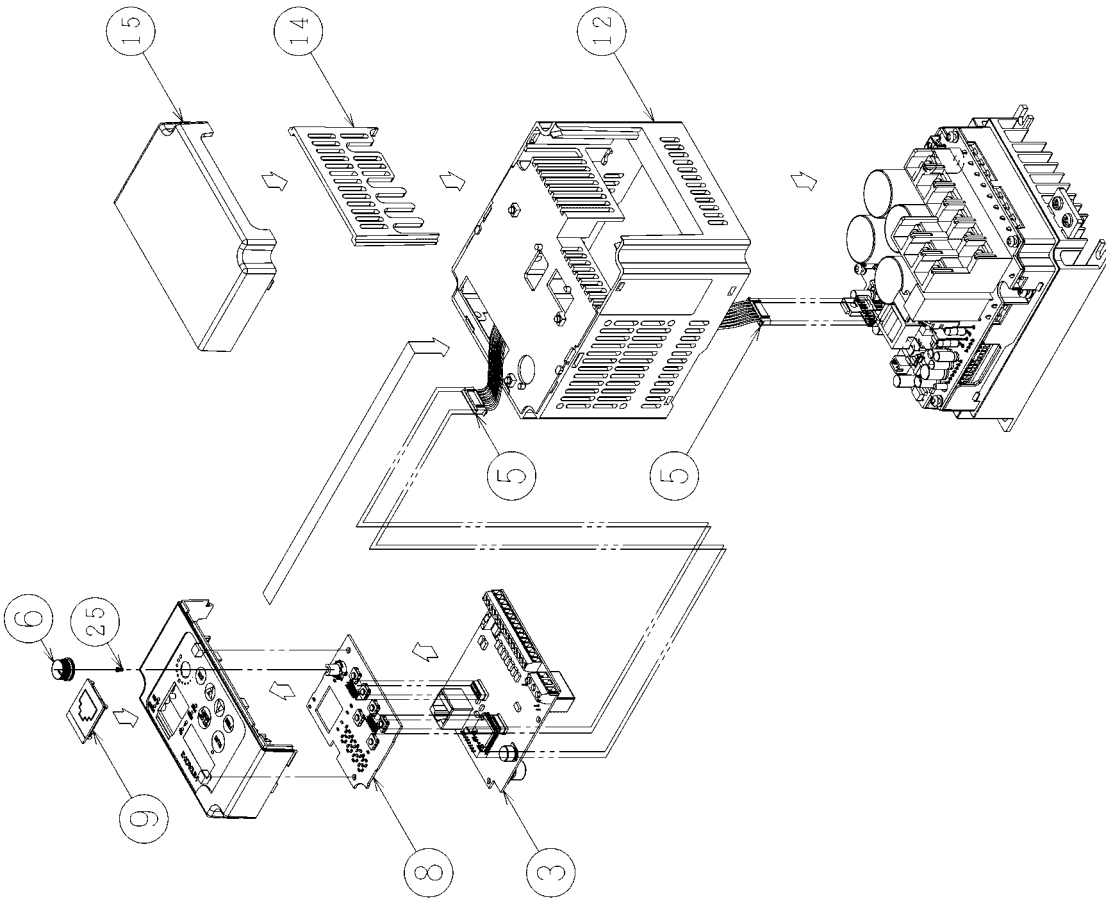

品番	部品略称	部品名	1 台分 使用数量
3	P/IP	PCB3基板	1
5	WIRE	通線ケーブル	1
6	CS	ポリウムツマミ	1
8	P/SUB	PCB4基板	1
9	CV	ブラグカバ-	1
12	CS	ケース	1
13	CV	表面カバ-	1
14	CV	リアカバ-	1
15	CV	フロントカバ-	1
25	SC	M1.4×4	1

御注文主	CUSTOMER	数量	QTY.	受注番号	ORDER No.	作業番号	WORK No.	REV.
	Hitachi	股		L200-004HFR		NARASHINO WORKS	DWG.No.	
DIV. N. Yokohama							3243T829834	SH.
CHD. M. HIRATA				構造 <input checked="" type="checkbox"/>				
APPD. A. MAKAMURA								

5.1.構造図(10/11)

CAD

1 2 3 4 5 6 7 8

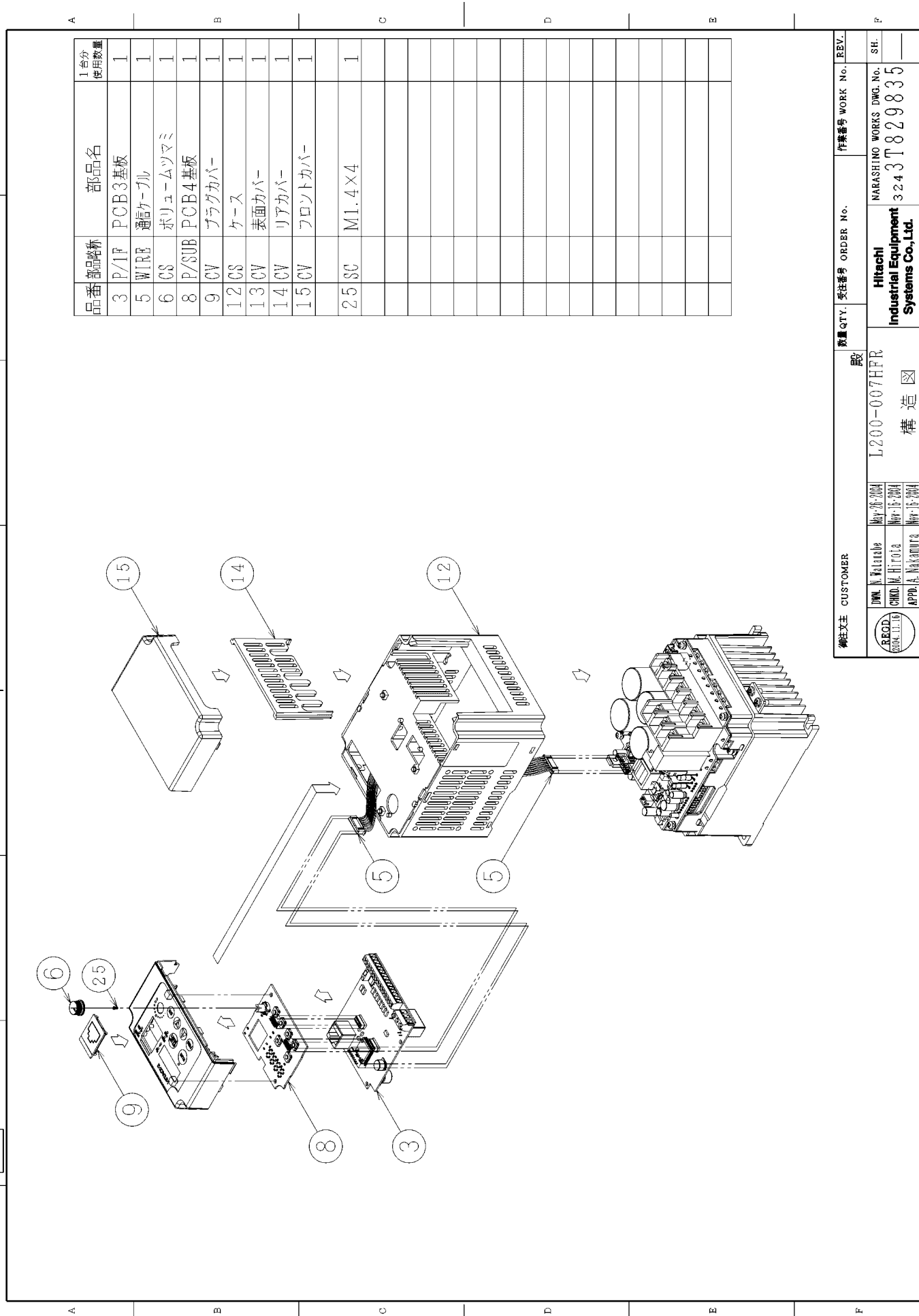

品番	部品略称	部品名	1台分 使用数量
3	P/IP	PCB3基板	1
5	WIRE	通信ケーブル	1
6	CS	ポリウムツマミ	1
8	P/SUB	PCB4基板	1
9	CV	プラグカバー	1
12	CS	ケース	1
13	CV	表面カバー	1
14	CV	リアカバー	1
15	CV	フロントカバー	1
25	SC	M1.4×4	1

御注文者 CUSTOMER		数量 QTY.	受注番号 ORDER No.	作業番号 WORK No.	REV.
Hitachi Industrial Equipment Systems Co., Ltd.		1	L200-007HFR	3243T829835	
NARASHINO WORKS					
Hitachi Industrial Equipment Systems Co., Ltd.					
構造 <input checked="" type="checkbox"/>					
枠番 FRAME SIZE					
DWN. N. Wakabayashi		May-20-2004			
CHD. M. Hirota		May-16-2004			
APPD. A. Makimoto		May-15-2004			

5.1.構造図(11/11)

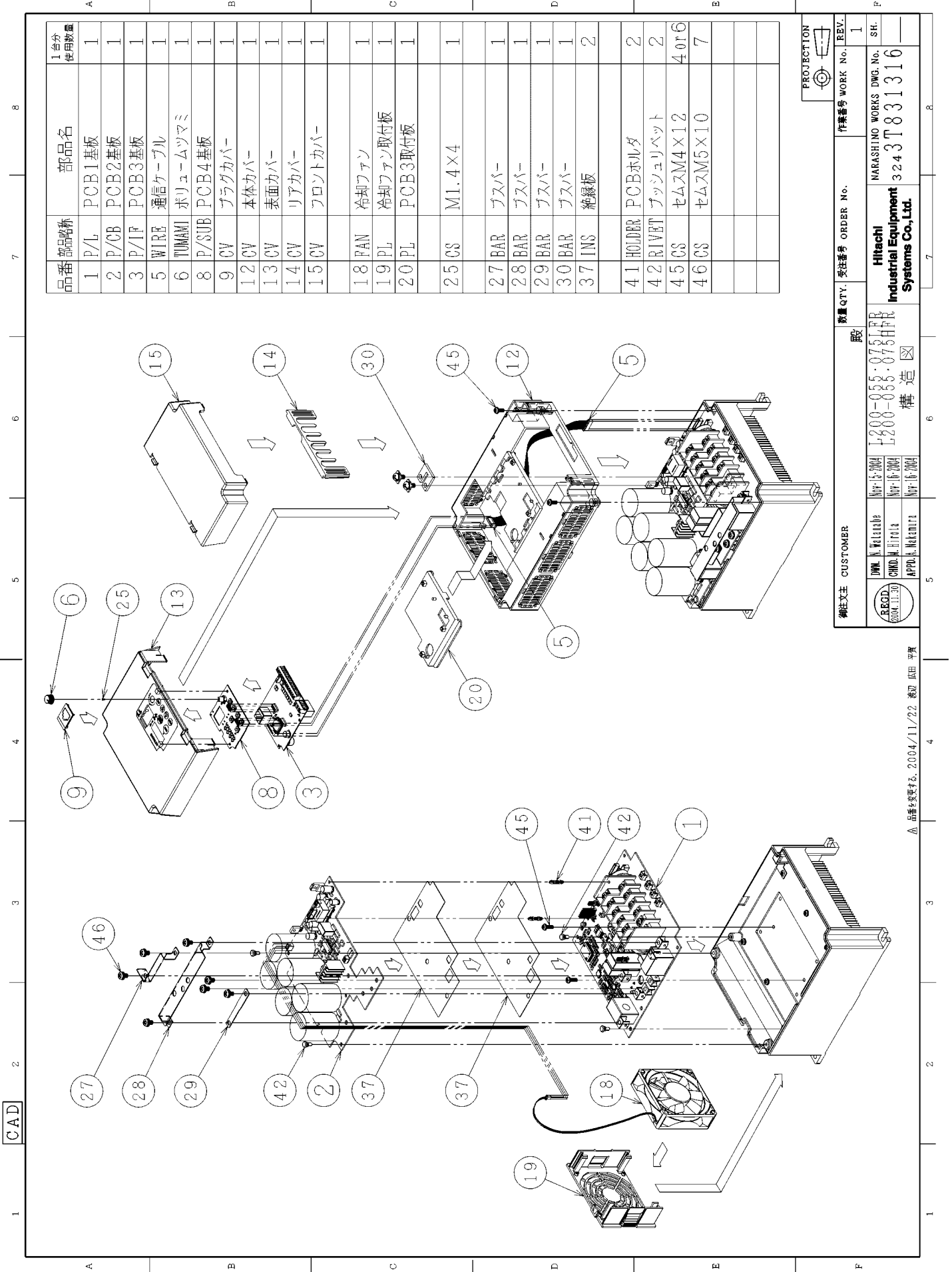

品番	部品名称	部品名	1台分 使用数量
1	P/L	PCB1基板	1
2	P/OB	PCB2基板	1
3	P/IP	PCB3基板	1
5	WIRE	通信ケーブル	1
6	TUMAMI	ポリウレタンツマミ	1
8	P/SUB	PCB4基板	1
9	CV	プラグカバー	1
12	CV	本体カバー	1
13	CV	表面カバー	1
14	CV	リアカバー	1
15	CV	フロントカバー	1
18	FAN	冷却ファン	1
19	PL	冷却ファン取付板	1
20	PL	PCB3取付板	1
25	CS	M1.4×4	1
27	BAR	ガスバー	1
28	BAR	ガスバー	1
29	BAR	ガスバー	1
30	BAR	ガスバー	1
37	INS	絶縁板	2
41	HOLDER	PCBホルダ	2
42	RIVET	フッソリベット	2
45	CS	セムSM4×12	4or6
46	CS	セムSM5×10	7

PROJECTION

数量 QTY. 受注番号 ORDER No. 件番 WORK No. REV. 1

編 製

日立 Hitachi  
Industrial Equipment  
Systems Co., Ltd.

2004.11.30  
RECD. 坂田 平貴  
2004.11.10  
CHKD. 坂田 平貴  
2004.10.16  
APPD. 坂田 平貴

顧客 CUSTOMER

200-055-0751PR  
200-055-0751PR

3243T831316

SH. 1

△ 品番変更する。2004/11/22 坂田 平貴

CAD

SJ200-002/004/005NFEF(Slide type)

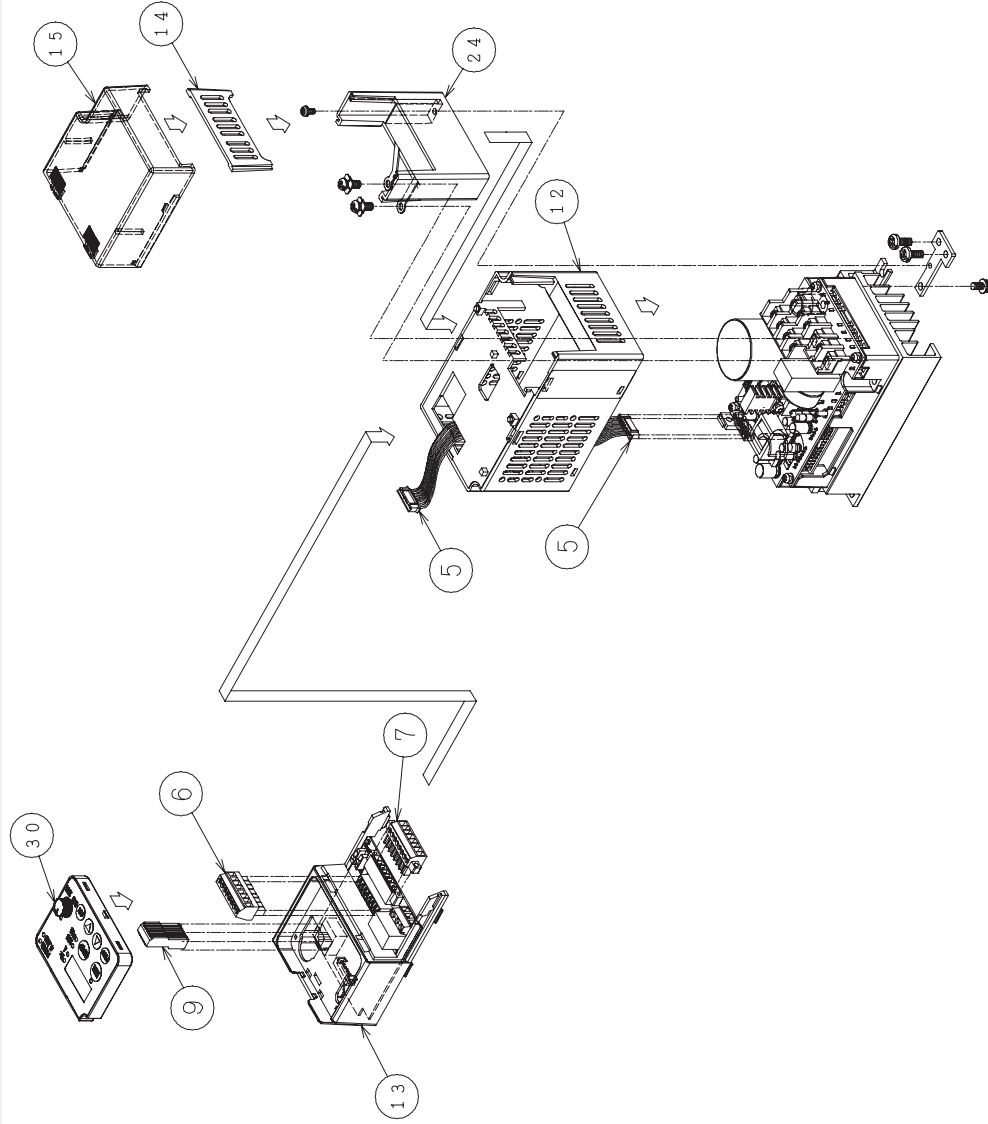

No.	Minidin	Name of parts	Quantity in Unit
5	WIRE	Cable	1
6	PLG	Terminal Plug A (TM1C)	1
7	PLG	Terminal Plug B (TM2C)	1
9	PLG	Plug	1
12	CS	Case	1
13	CV	Front Cover	1
14	CV	Housing Partition	1
15	CV	Housing Cover	1
24	FIL	Filter	1
30	KB	Volume Knob	1

圖號 DRAWING NO.	SJ200-002-004-005NFEF	數量 QTY.	1	作業順序 WORK NO.	
客戶 CUSTOMER	Hitachi Industrial Equipment Systems Co., Ltd.	圖名 TITLE	SJ200-002-004-005NFEF	零件圖號 PART NO.	32489
製圖 DRAWN	T. Kimura	檢核 CHECKED		組裝圖 ASSEMBLY	
繪圖 DESIGNED	N. Tsuji	工程 ENGINEER		圖名 TITLE	Structure diagram

SJ200-007/011NFEF/004/007HFEF (Slide type)

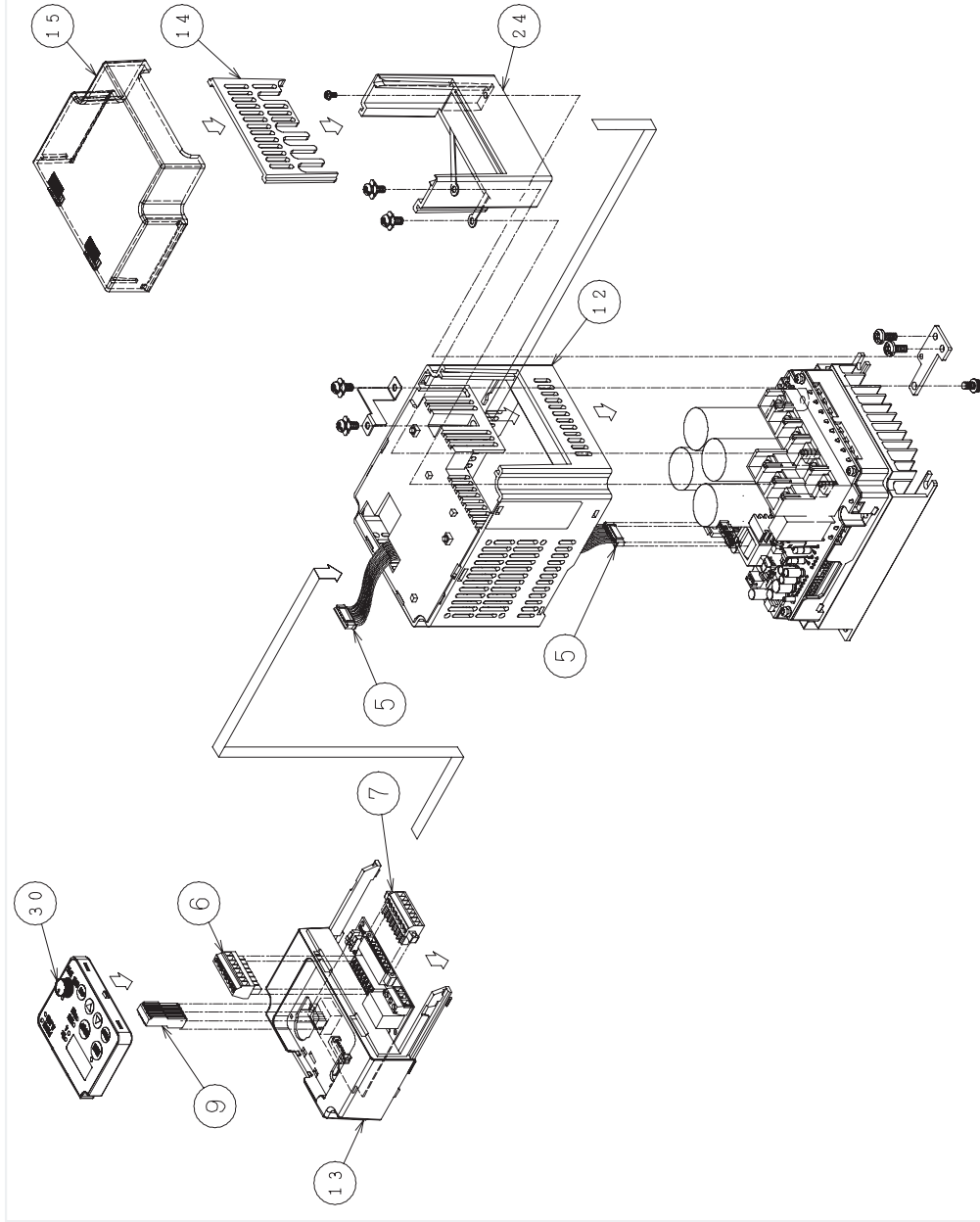

No.	Whititin	Name of parts	Quantity in Unit
5	WIRE	Cable	1
6	PLG	Terminal Plug A (TW1C)	1
7	PLG	Terminal Plug B (TW2C)	1
9	PLG	Plug	1
12	CS	Case	1
13	CV	Front Cover	1
14	CV	Housing Partition	1
15	CV	Housing Cover	1
24	FIL	Filter	1
30	KB	Volume Knob	1

製造元: 日立製作所	製造番号: 007HFEF	作業番号: W00K-001-0001
図面: 004/007HFEF	図名: 構造図	
図面番号: SJ200-007-011NFEF	図名: Hitachi Industrial Equipment Systems Co., Ltd.	
図面番号: SJ200-004-007HFEF	図名: KARASHINO DWA. NO.	図面番号: 3243T832500
図面番号: 004/007HFEF	図名: Structure diagram	
図面番号: 004/007HFEF	図名: Structure diagram	

SJ200-015/022NFEF-015~040HFEF (Slide type)

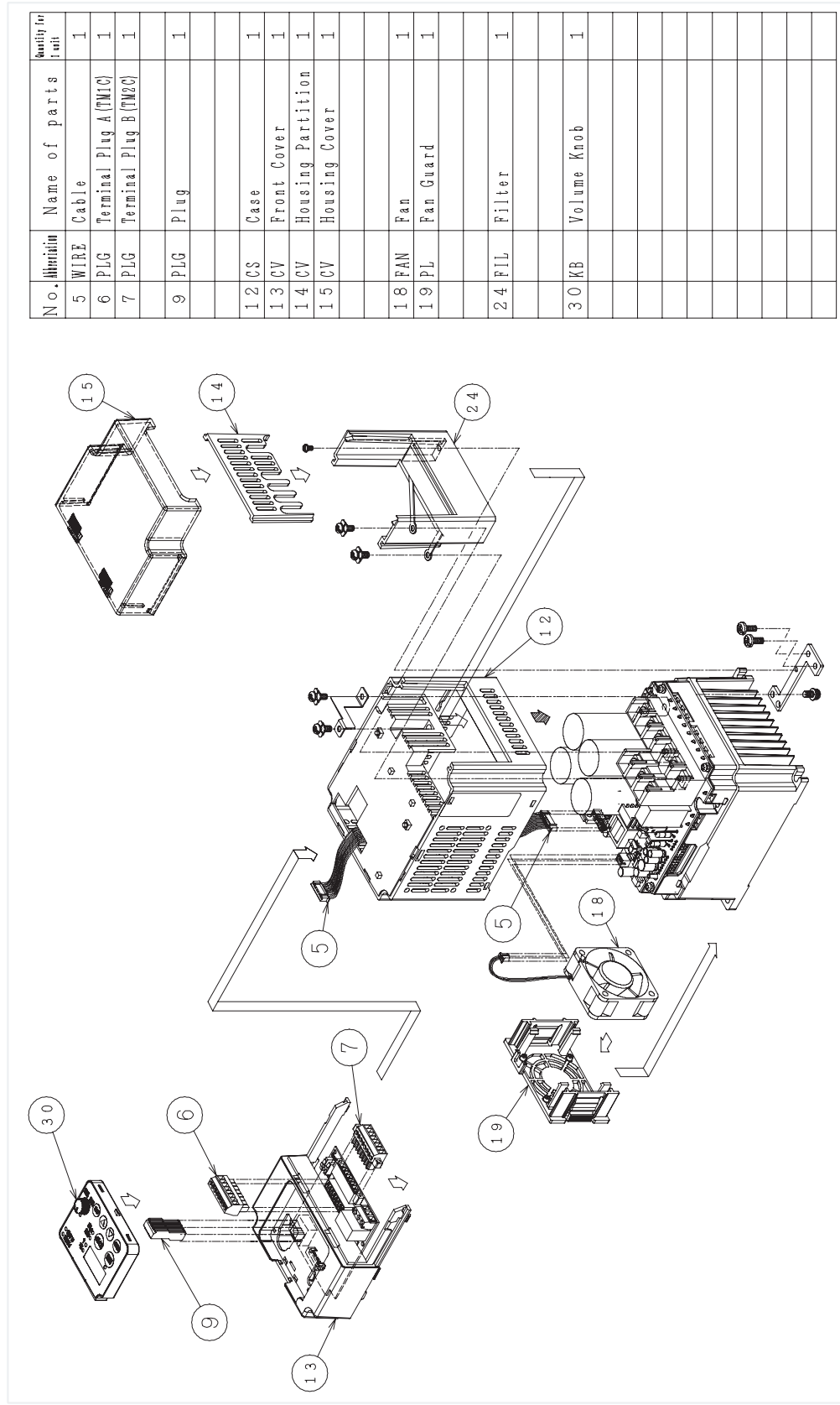

No.	Illustration	Name of parts	Quantity for Unit
5	WIRE	Cable	1
6	PLG	Terminal Plug A (TM1C)	1
7	PLG	Terminal Plug B (TM2C)	1
9	PLG	Plug	1
12	CS	Case	1
13	CV	Front Cover	1
14	CV	Housing Partition	1
15	CV	Housing Cover	1
18	FAN	Fan	1
19	PL	Fan Guard	1
24	FIL	Filter	1
30	KB	Volume Knob	1

販売店 CUSTOMER	原機型 ORDER NO.	作業番号 WORK NO.
東芝 T. Kimura	SJ200-015-022NFEF	
日立 M. Tsuji	SJ200-015~040HFEF	
	Structure diagram	
	Hitachi Industrial Equipment Systems Co., LTD.	
	Hitachi Industrial Equipment	
	3243TB32501	

# SJ200-055/075HFEF (Slide type)

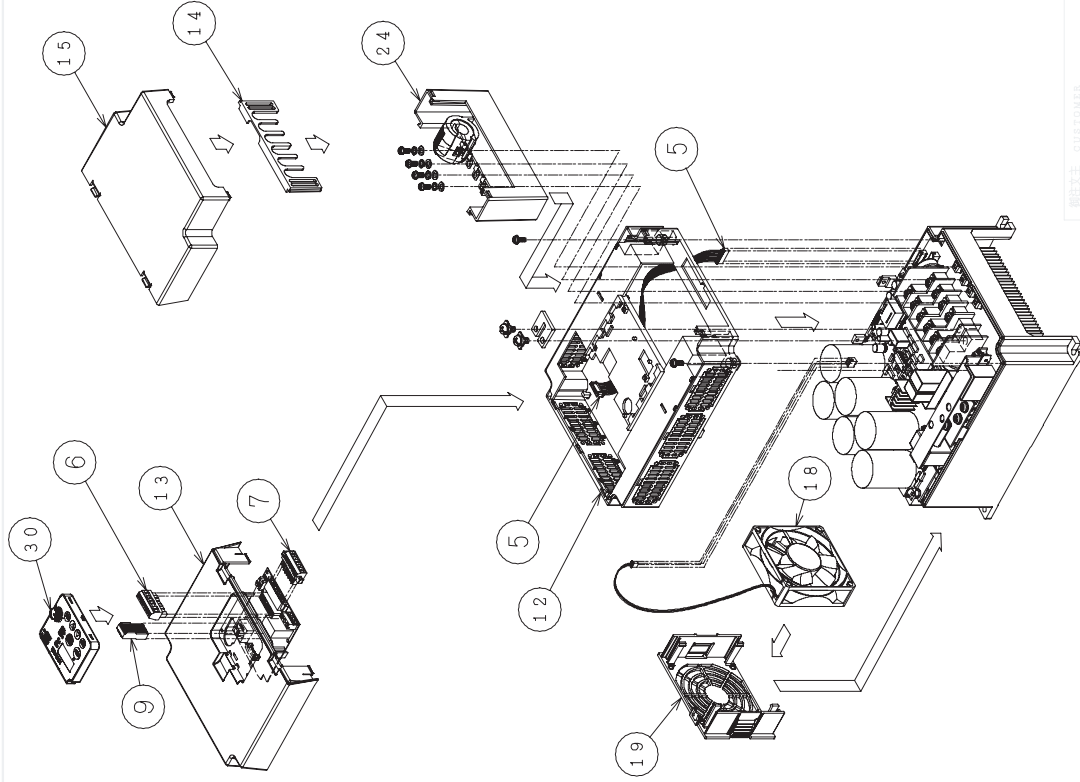

No.	Minimin	Name of parts	Quantity in unit
5	WIRE	Cable	1
6	PLG	Terminal Plug A(TW1C)	1
7	PLG	Terminal Plug B(TW2C)	1
9	PLG	Plug	1
12	CS	Case	1
13	CV	Front Cover	1
14	CV	Housing Partition	1
15	CV	Housing Cover	1
18	FAN	Fan	1
19	PL	Fan Guard	1
24	FIL	Filter	1
	FIL	Core	1
	PL	Core Holder	1
	SC	Screw	4
	W	Washer	4
	SP.W	Spring Washer	4
30	KB	Volume Knob	1

数量訂正 変更番号 ORDER NO. 行先番号 WORK NO. 図式  
 Hitachi Industrial Equipment Systems Co., Ltd.  
 Hitachi Industrial Equipment Systems Co., Ltd.  
 KARASHINO DWG. NO. 3243TB32502  
 Structure diagram



L200-002/004/005NFEF (Slide type)

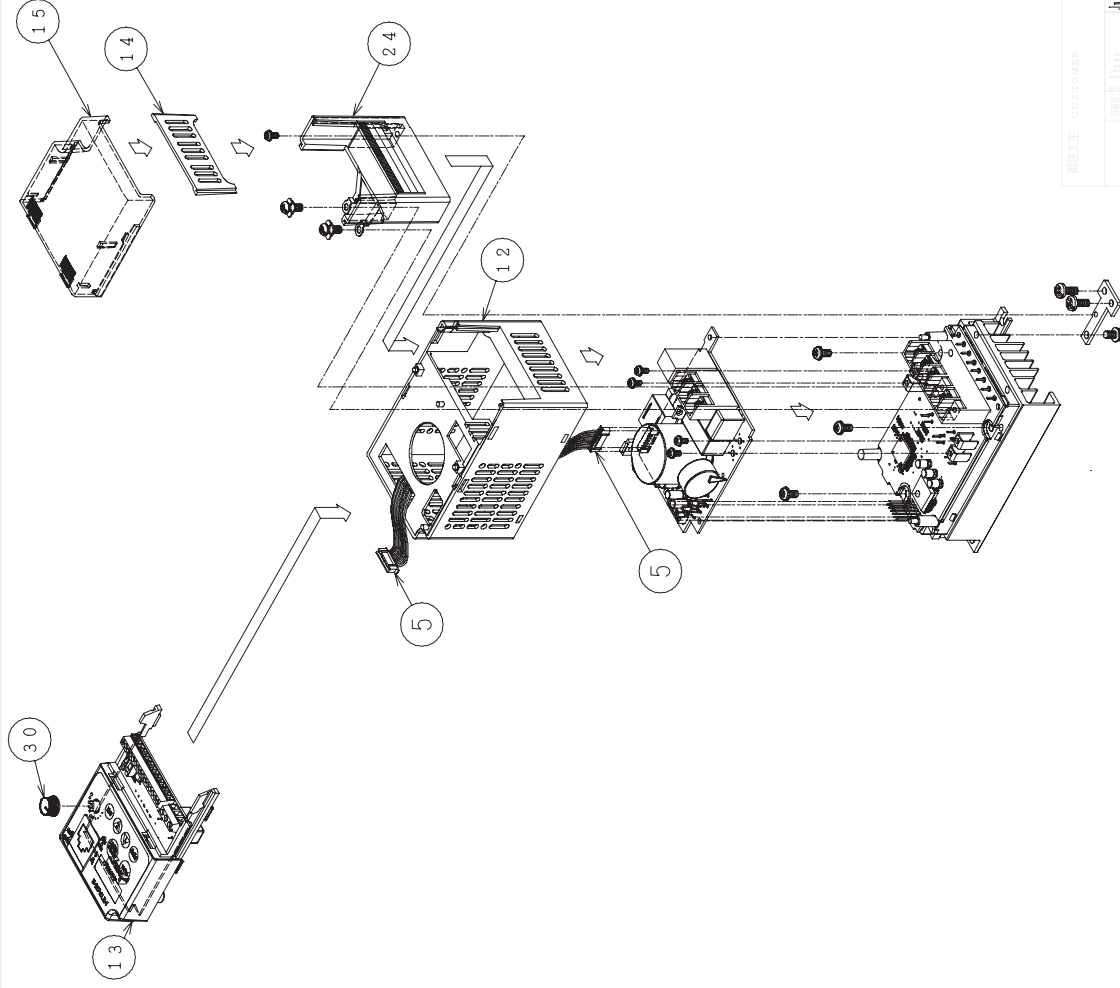

No.	Illustration	Name of parts	Quantity in unit
5		WIRE Cable	1
12		Case	1
13		Front Cover	1
14		Housing Partition	1
15		Housing Cover	1
24		FIL Filter	1
30		KB Volume Knob	1

顧客名 CUSTOMER 日立製作所  
 代表者 REPRESENTATIVE 代表取締役 藤原 正雄  
 電話 TEL. 03-5643-2503  
 図番 DRAWING NO. L200-002-004-005NFEF  
 機番 MACHINE NO. 1200-002-004-005NFEF  
 品番 PART NO. JH-B-005  
 製作所 MANUFACTURE 日立製作所 日立製作所 日立製作所  
 品名 NAME OF EQUIPMENT 工業用機器 Industrial Equipment  
 図名 TITLE OF DRAWING 構造図 Structure diagram  
 図号 DRAWING NO. 3832503  
 発注番号 ORDER NO.  
 作業番号 WORK NO.

L200-004/007HFEF-007NFEF (Side type)

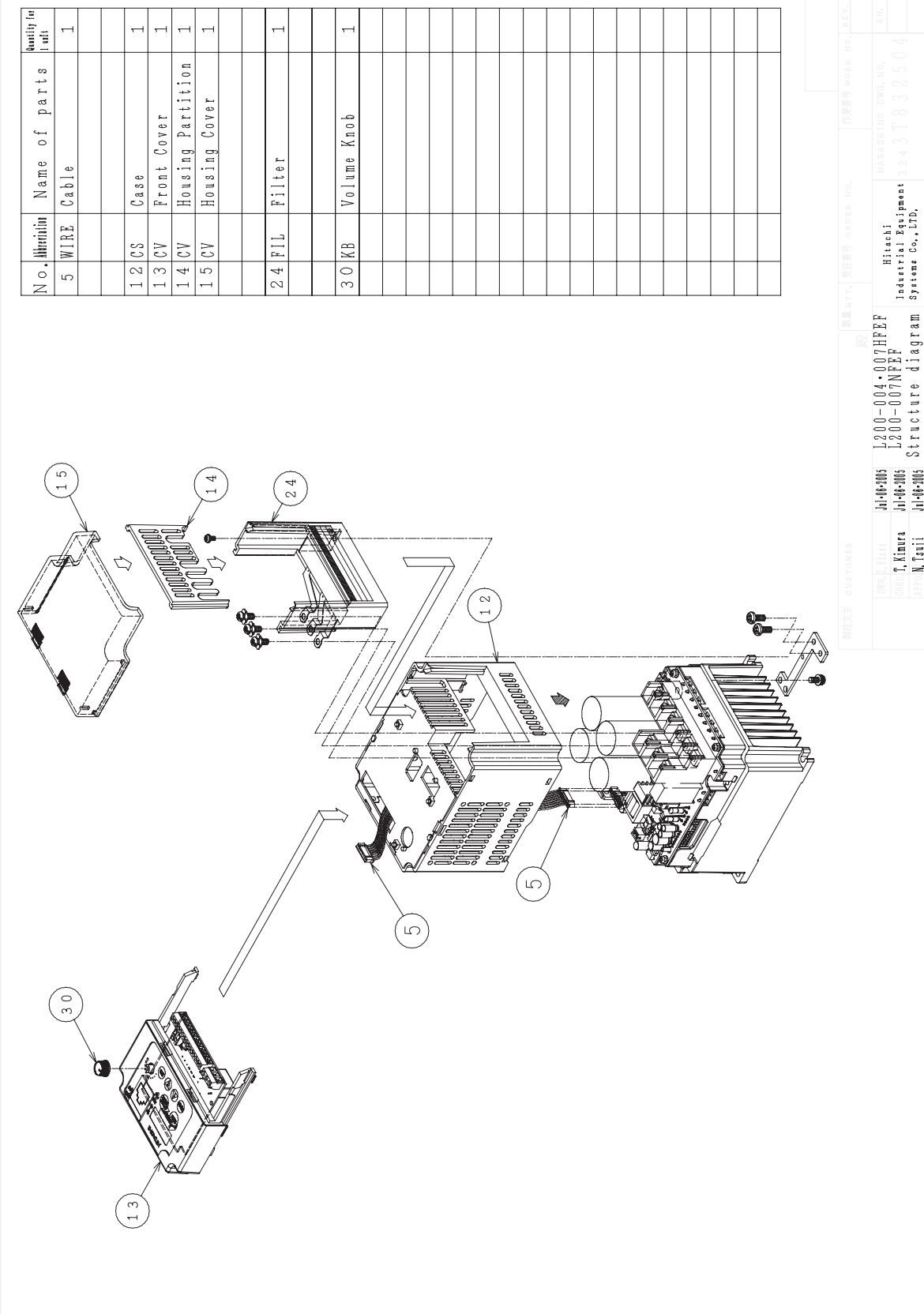

No. Illustration	Name of parts	Quantity in Unit
5 WIRE	Cable	1
1 2 CS	Case	1
1 3 CV	Front Cover	1
1 4 CV	Housing Partition	1
1 5 CV	Housing Cover	1
2 4 FIL	Filter	1
3 0 KB	Volume Knob	1

原機主名 OEM PARTS	数量 QTY	発注番号 ORDER NO.	作業番号 WORK NO.	型式 TYPE
日立製作所 Hitachi Ltd.	L200-004-007HFEF	日立製作所 Hitachi Industrial Equipment Systems Co., Ltd.	作業番号 WORK NO.	型式 TYPE
田中 幸次 Yukio Tanaka	L200-007NFEF	Structure diagram	作業番号 WORK NO.	型式 TYPE
山本 孝次 Takashi Yamamoto			作業番号 WORK NO.	型式 TYPE
佐藤 孝次 Takashi Sato			作業番号 WORK NO.	型式 TYPE