

# HITACHI

## Inspire the Next

### **Application Note: Powering Inverters from a DC Supply**

**Please refer also to the  
Inverter Instruction Manual**

**AN091802-1 Rev B**

**Hitachi Industrial Equipment & Solutions America, LLC**

© Hitachi Industrial Equipment & Solutions America, LLC. 2021.

# Powering Inverters from DC

It is possible to power inverters from a DC Power source, or to connect the DC Bus of multiple inverters together to achieve energy savings, since inverters in power driving mode can use power from those that are in regeneration mode.

## [1] Connection method

There are several ways for DC bus connection of the inverters. (Examples of 3-phase 200V or 400V class inverter.)

Case 1: Connected in parallel to a common DC bus

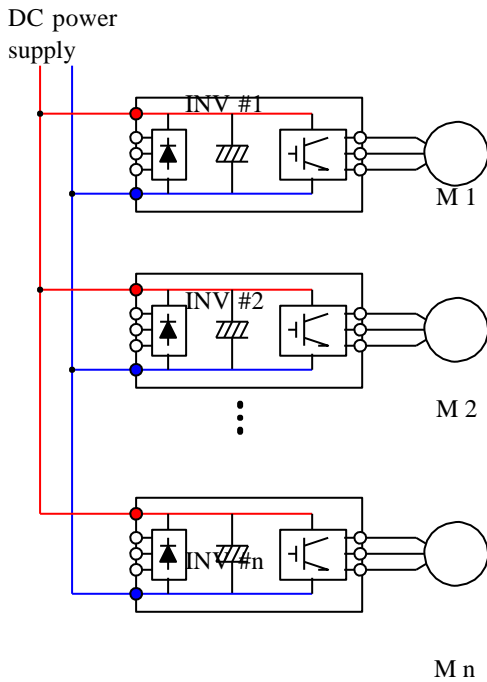

Case 2: Connected in parallel to an AC-fed inverter

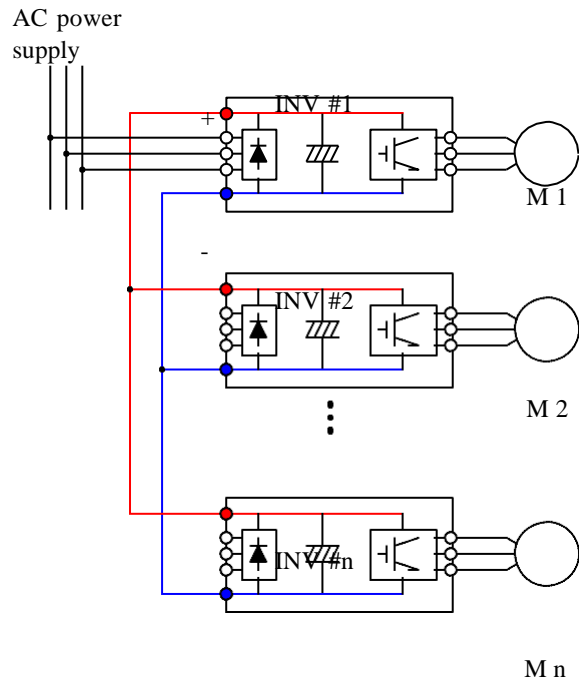

Case 3: AC & DC Connected together

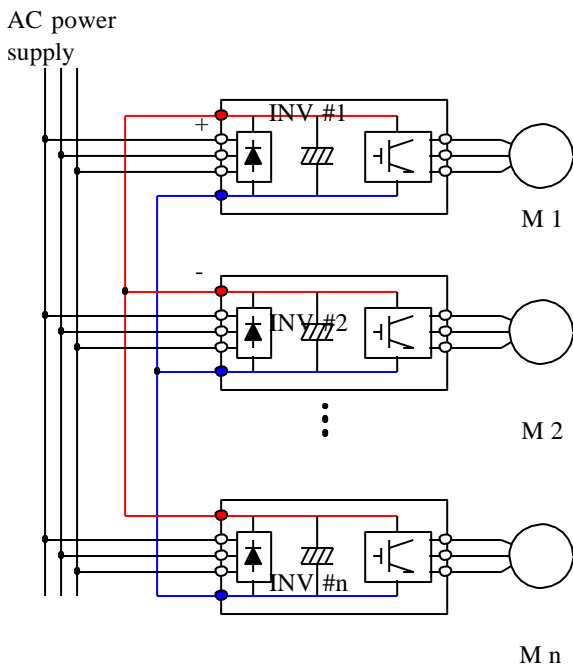

Case 4: DC supply connection methods

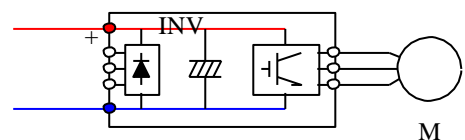

☐ Connecting to + and - terminal

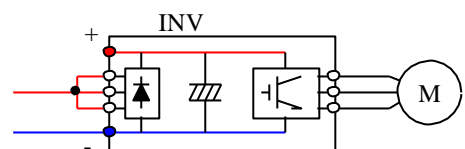

⌚ Connecting to AC inputs and - terminal

☆ Advantage and disadvantages of Case 4 connection method.

Item	Contents	Advantage	Disadvantage
☐	Connecting to + & - terminal	⊕ No concern for the rectifier bridge diodes.	⊖ There will be no inrush current limiting.
⌚	Connecting to AC inputs and - terminal	⊕ Integrated inrush current limiting circuit is used.	⊖ Rectifier bridge diodes of the main inverter may need to be up-sized.

[2] DC voltage to be supplied

Model	Class	UV	BRD On	OV (regen)	OV source
NES1	200V	UV:175+-10VDC RETRY: 195+-10VDC	ADJUSTABLE BY b096 330-380VDC	400+-10VDC	390+-10VDC HOLDS 100S
	400V	UV:345+-10VDC RETRY: 390+-20VDC	ADJUSTABLE BY b096 660-760VDC	800+-20VDC	780+-20VDC HOLDS 100S
WJ200	200V	UV:172.5+-10VDC UV RETRY: 195+-10VDC	ADJUSTABLE BY b096 330-380VDC	400+-10VDC	390+-10VDC HOLDS 100S
	400V	UV:345+-10VDC RETRY: 390+-20VDC	ADJUSTABLE BY b096 660-760VDC	800+-20VDC	780+-20VDC HOLDS 100S
SJ700(D)	200V	UV:175+-10VDC RETRY: 195+-10VDC	ADJUSTABLE BY b096 330-380VDC	400+-10VDC	390+-10VDC HOLDS 100S
	400V	UV:345+-10VDC RETRY: 390+-20VDC	ADJUSTABLE BY b096 660-760VDC	800+-20VDC	780+-20VDC HOLDS 100S
SJ-P1	200V	UV:175+-10VDC RETRY: 195+-10VDC	ADJUSTABLE BY b096 330-380VDC	400+-10VDC	390+-10VDC HOLDS 100S
	400V	UV:345+-10VDC RETRY: 390+-20VDC	ADJUSTABLE BY b096 660-760VDC	800+-20VDC	780+-20VDC HOLDS 100S

[3] Cautions

**Case 1 : Connected parallel to a common DC net**

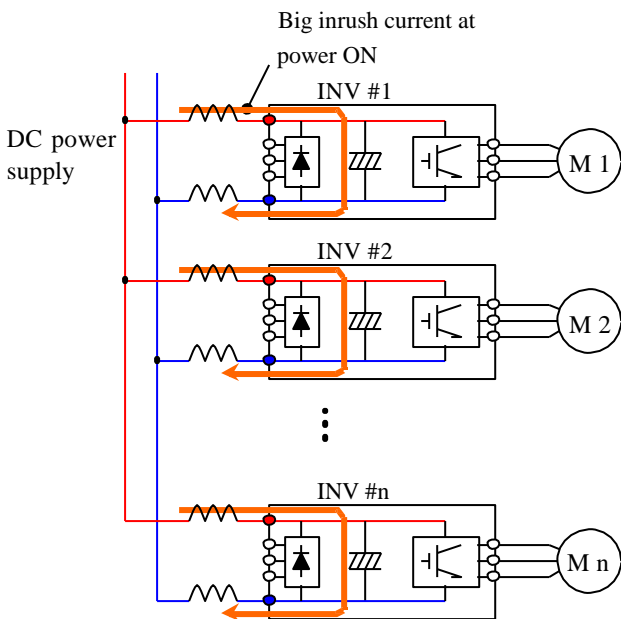

- ✧ Take preventive measures to limit inrush current at power ON, since the integrated inrush current limiting circuit is not used.
  - ☒ Otherwise there will be an unexpected UV at net side or damage to the inverter caused by  $\Delta V=di/dt$ .
- ✧ Use DC chokes for each inverter to avoid interaction due to surge and/or harmonics.
  - ☒ Otherwise there may be an unexpected failure of the inverter or other attached equipment.
- ✧ Take preventive measures to ensure sufficient time between UV level and dead voltage of the DC/DC converter (\*1) at power OFF. This is to allow ample time for EEPROM to store the existing data at power OFF. ( $\Delta t$ ; see below)
  - ☒ Otherwise there is a possibility of an EEPROM error at the next power ON.

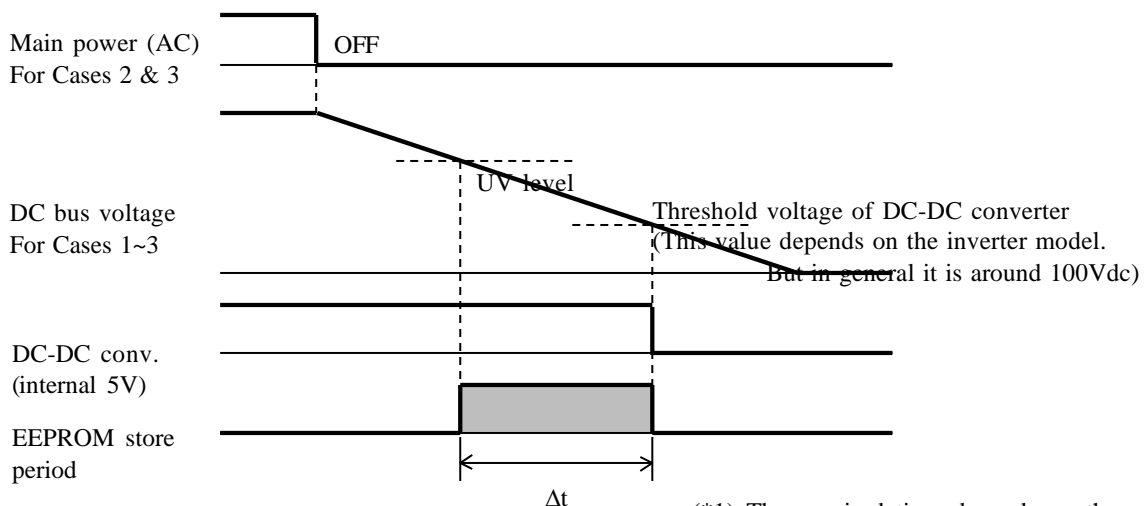

(\*1) The required time depends on the parameters which have changed before power OFF. Around 0.5~1s or more

## Case 2 : DC Bus connected n parallel to a single AC-fed inverter

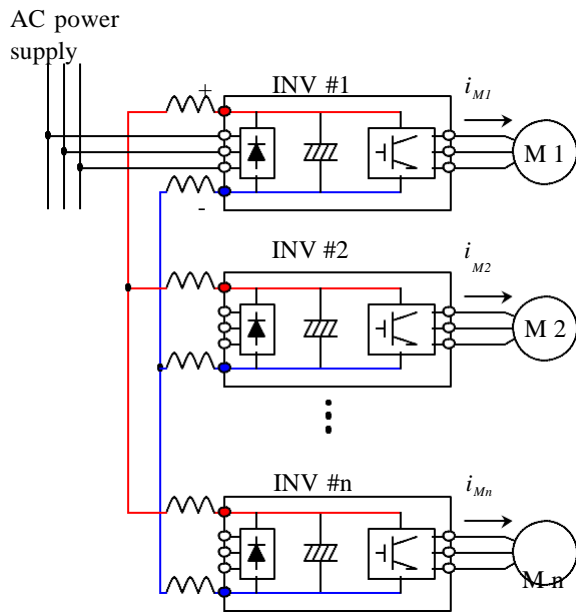

☆ **Pay attention to the selection of the main inverter (#1) because all the input current flows through the rectifier bridge of this inverter. (\*2)**

☆ Need sufficient time for EEPROM to store the data. (Refer to Case 1)

☆ Use DC choke. (Refer to Case 1)

<Selection of the main inverter kW>

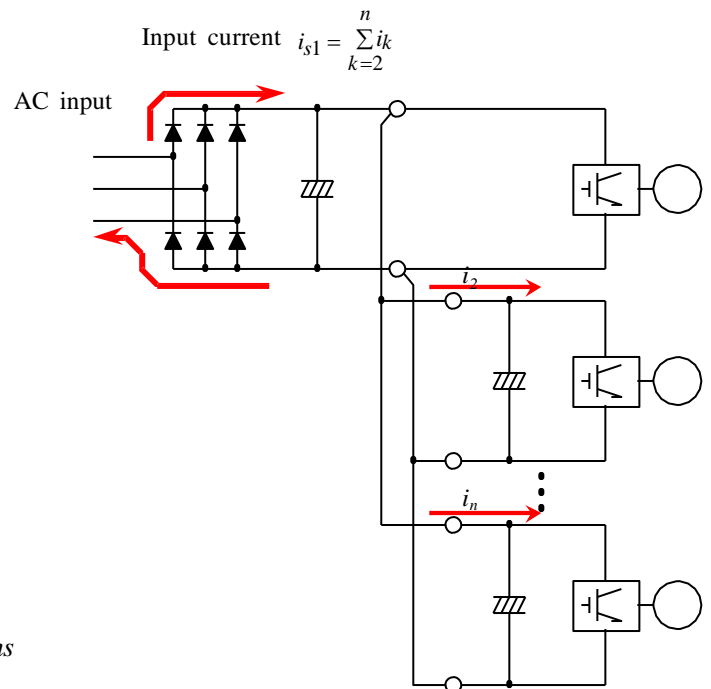

(\*2) Capacity of the main inverter

Rated current of the main inverter should be higher than;

- ☆ Total rated current of the inverters
- and
- ☆ Possible highest total motor current

[Example of 4 inverters in parallel]

- ☆ INV#1~#4=SJ700-040HFxF2 (9.0 A rated)
- ☆  $i_{M1(max)} = i_{M2(max)} = i_{M3(max)} = i_{M4(max)} = 9.5 \text{ Arms}$

In this case, the total motor current under the possible worst case is higher than that of the inverters.

$$\text{Total inverter rated current} = i_1 + i_2 + i_3 + i_4 = 9.0 * 4 = 36 \text{ Arms}$$

$$\text{Total motor current under possible worst case} = i_{M1(max)} + i_{M2(max)} + i_{M3(max)} + i_{M4(max)} = 38 \text{ Arms}$$

- ☒ Main inverter must therefore be P1-00470-HFUF (38A) or larger. P1-00620-HFUF is suggested to provide additional safety margin.